

# SUPER AUTO EJECT

## AUTOMATIC SHORELINE DISCONNECT



**MODEL # : 091-55-15-DC**  
**MODEL # : 091-55-15-120**  
**MODEL # : 091-55-20-120**

File: IM\_091-55\_revN.indd  
Rev: N (page 3,6)  
Revised By: SO  
Date: 03-17-2016

2 YEAR WARRANTY

---

170 Cherry Avenue  
West Sayville, NY 11796  
[www.kussmaul.com](http://www.kussmaul.com)

**KUSSMAUL™**  
**ELECTRONICS**  
*ENERGIZED AND READY, WHEN SECONDS COUNT*

Ph: 800-346-0857  
Fax: 631-567-5826  
[sales@kussmaul.com](mailto:sales@kussmaul.com)

# INTRODUCTION

The Super Auto Eject is a completely sealed power input connector designed to be mounted anywhere on the vehicle to permit connecting the shoreline. This sealed unit prevents contamination of the mechanism by road dirt, and ensures long reliable life even when mounted in the most severe environment. A novel internal switch arrangement closes and opens the incoming power to the vehicle after the mating connector is inserted, and before the connector is removed. This eliminates arcing at the connector contacts, and assures long contact life. It comes with a weatherproof cover. The cover is spring loaded to close, preventing water from entering when the shoreline is not connected. This simple, reliable device, eliminates forever the broken cables which result when drivers forget to remove the shoreline before driving away.

# INSTALLATION INSTRUCTIONS

## I. MOUNTING THE SUPER AUTO EJECT

1. Locate a convenient place on the vehicle to mount the Super Auto Eject. A minimum clearance of 3" behind the mounting panel is required.
2. Place the template in position and center punch in 5 places, see Figure 1 Hole Template.
3. Drill 4 mounting holes, 3/16" diameter and one, 1 3/4" clearance hole for the Super Auto Eject.

## II. FIGURE 1, HOLE TEMPLATE FOR THE SUPER AUTO EJECT

1. Note: When printing this page, use the print setting "Actual Size" otherwise may not print to scale

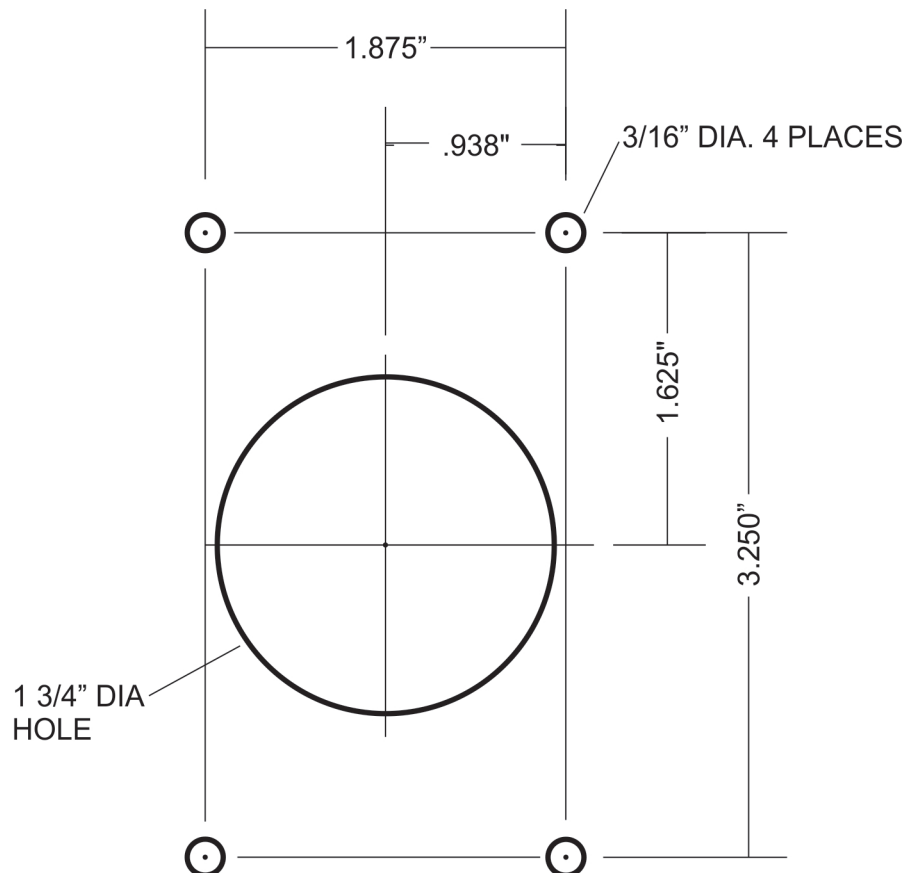

### III. WIRING THE SUPER AUTO EJECT

1. On the 2 conductor cable, connect the Black Wire to the vehicle's ground and the White Wire the vehicle's starter and install a 4 Amp Fuse inline. Use a minimum of 16 AWG wire.
2. On the 3 conductor cable, use the butt splices provided to connect the Green, Black, and White power wires to the accessories on the vehicle. For Model #'s: 091-55-15-DC and 091-55-15-120, use a minimum of 14 AWG wire. For Model #: 091-55-20-120, use a minimum of 12 AWG wire.

### IV. FIGURE 2, WIRING THE SUPER AUTO EJECT

1. Note: Connect the starter circuit so that the solenoid is energized only while the engine is cranking. If the solenoid is energized continuously it will OVERHEAT and BURN OUT and void the warranty.

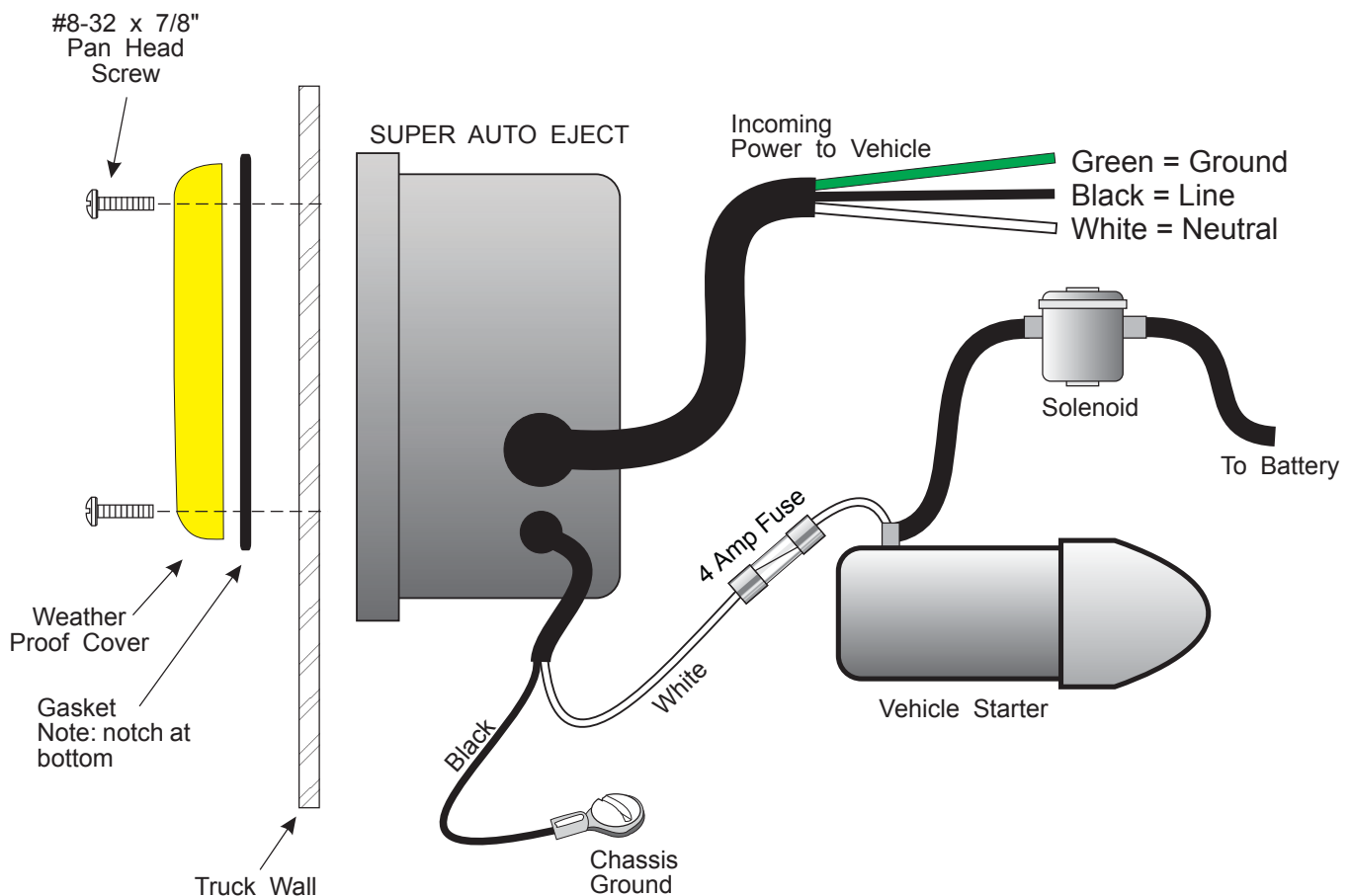

# TEST AND OPERATION

---

## I. ELECTRICAL TEST

Inspect and verify that all wiring is properly connected as illustrated in figure 2. Measure the D.C. voltage across the solenoid. Cranking the engine should create a D.C. voltage approximately equal to the battery voltage and simultaneously cause the plug to eject.

## II. OPERATION

Install the connector in the Super Auto Eject and note that A.C. power is applied to the vehicle mounted battery charger. Verify that cranking the engine ejects the shoreline.

# NOTES AND CAUTIONS

---

## I. STARTER CIRCUIT

The Super Auto Eject must be connected to the starter circuit so that the solenoid is energized only while the engine is cranking. If the solenoid is energized continuously it will OVERHEAT and BURN OUT.

## II. CONNECTOR INSTALLATION

Do not permit the shore line to drop to the floor when it is ejected. Keep from falling by utilizing a bungee cord restraint, cord reel, optional Auto Reel or some other device. Dropping the connector may result in damage or breakage. Kussmaul Electronics does not warrant the connector.

## III. USING THE CORRECT CONNECTORS

The Super Auto Eject is supplied with mating connector. Do not replace with similar connectors. Use only the Kussmaul Electronics supplied connector.

## IV. ANNUAL MAINTENANCE

1. Keep connector and contacts of the Super Auto Eject clean.
2. Clean contacts with WD-40 solvent as required.
3. Lubricate contacts monthly with "vaseline" to insure free operation.
4. Check all gaskets and replace if worn.

## V. WARRANTY IMPACT

Failure to follow these notes and cautions will void the warranty

# OPTIONAL ACCESSORIES

## I. E-Z MOUNTING PLATE, MODEL #: 091-185-009

- Provides an easier installation of the Super Auto Eject
- Shows an indication of when the line cord has been connected properly
- Green Watertight LED indicator



## II. AUTO REEL, MODEL #: 091-220-20-120

- Automatic shoreline retraction and storage compatible with Auto Eject or by manual disconnection
- Reduce tripping hazard and liability by removing hazardous cord on the ground
- Increase productivity during emergency dispatch by automating the electrical disconnection process
- Ceiling or Wall mounted – Curved edges for Safe and Easy mounting



## III. POWER CORD REEL, MODEL #: L4545 12 3 3

- 45 foot, 12 AWG, 3 conductor cord
- Spring retractable with latch
- Wall or ceiling mount
- Adjustable cord stop



## IV. RUBBER CONNECTOR PROTECTOR, MODEL #: 091-55-069

- Covers the female 5-15P-H, 6-15P-H, or 5-20P-H connector with 1/8" rubber to protect the connector and nearby vehicles from impact damage



# SPECIFICATIONS

---

**Input Voltage:** 12 VDC Nominal (10-15 VDC)

**Input Current:** 3.1 Amperes Max

**Electrical Rating:**

**Model #: 091-55-15-DC:** 12 Volts DC or 250 Volts AC, 15 Amperes Max

**Model #: 091-55-15-120:** 120 Volts AC, 15 Amperes Max

**Model #: 091-55-20-120:** 120 Volts AC, 20 Amperes Max

**Hardware Pack Provided:** 3 Butt Splices, cover with gasket and mounting screws, mating connector

**Weight:** 4 pounds

# INSTALLATION RECORD

---

DATE INSTALLED \_\_\_\_\_

INSTALLED BY \_\_\_\_\_

VEHICLE IDENTIFICATION \_\_\_\_\_

VEHICLE OWNER \_\_\_\_\_

# WARRANTY POLICY

---

All products of Kussmaul Electronics are warranted to be free of defects of material or workmanship. Liability is limited to repairing or replacing at our factory, without charge, any material or defects which become apparent in normal use within 2 years from the date the equipment was shipped. Equipment is to be returned, shipping charges prepaid and will be returned, after repair, shipping charges paid.

Kussmaul Electronics shall have no liability for damages of any kind to associated equipment arising from the installation and/or use of the Kussmaul Electronics products. The purchaser, by the acceptance of the equipment, assumes all liability for any damages which may result from its installation, use or misuse, by the purchaser, his or its employees or others.



Members of  
Fire and Emergency  
Manufacturers and  
Service Association



Members of  
National Fire  
Protection  
Association



Members of  
Fire Apparatus  
Manufacturers  
Association



170 Cherry Avenue  
West Sayville, NY 11796  
www.kussmaul.com



Ph: 800-346-0857  
Fax: 631-567-5826  
sales@kussmaul.com