

# SUPER AUTO EJECT DELUXE COVER WITH OLED DISPLAY



**MODEL # : 091-55-817XC-XX**

**FOR XANTREX INVERTER/CHARGER FREEDOM XC SERIES**

File: IM\_091-55-817CX-XX  
Rev: A  
Revised By: THN  
Date: 03-26-24

3 YEAR WARRANTY

---

170 Cherry Avenue  
West Sayville, NY 11796  
[www.kussmaul.com](http://www.kussmaul.com)

 **KUSSMAUL™**  
**ELECTRONICS**  
*ENERGIZED AND READY, WHEN SECONDS COUNT*

Ph: 800-346-0857  
Fax: 631-567-5826  
[sales@kussmaul.com](mailto:sales@kussmaul.com)

# INTRODUCTION

---

The new Super Auto Eject Deluxe Cover incorporates two products into one easy to install package. The Deluxe Cover features a remotely mounted volts and amps digital display. An OLED is used to display the Inverter/Charger output voltage and current.

The new lid design provides for 180-degree motion. This all-in-one package can be easily installed into existing and new Auto Eject installs.

## FEATURES

---

### I. NEW COVER DESIGN

- Incorporates Auto Eject cover and OLED into one product
- Lid on cover opens 180-degrees to prevent beakage
- OLED displays Inverter/Charger Volts and Amps output
- Includes rear mounted premolded rubber gasket for extra protect from the elements

### II. INCORPORATED OLED DISPLAY

When used with Xantrax XC Inverter/Charger, OLED displays chargers battery voltage and amperage. These easy to read display provide, immediate battery conditions.

### III. VOLTS & AMPS LED STATUS INDICATOR

#### **VOLTS LED:**

- Blinking RED: HIGH voltage or LOW voltage condition
- Blinking GRN: Charging
- Solid GRN: Charged (float mode)

#### **AMPS LED:**

- Blinking RED: Current-limit exceeded
- Solid RED: Battery is being discharged
- Solid GRN: Battery is charging
- OFF: Less than 2 amps output (float mode)

## INSTALLATION INSTRUCTIONS

---

### I. INSTALLATION

1. Follow instructions for installing the Auto Eject.
2. Place the template in position and center punch in 6 places, see Figure 1: Hole Template.
3. Drill 4 mounting holes, 3/16" diameter, one 1-3/4" clearance hole for the Super Auto Eject, and one hole for the indicator wiring cable.

### II. HOLE TEMPLATE: Figure 1

**Note:** When printing this page use the print setting "Actual Size", otherwise template may not print to scale.

# INSTALLATION INSTRUCTIONS

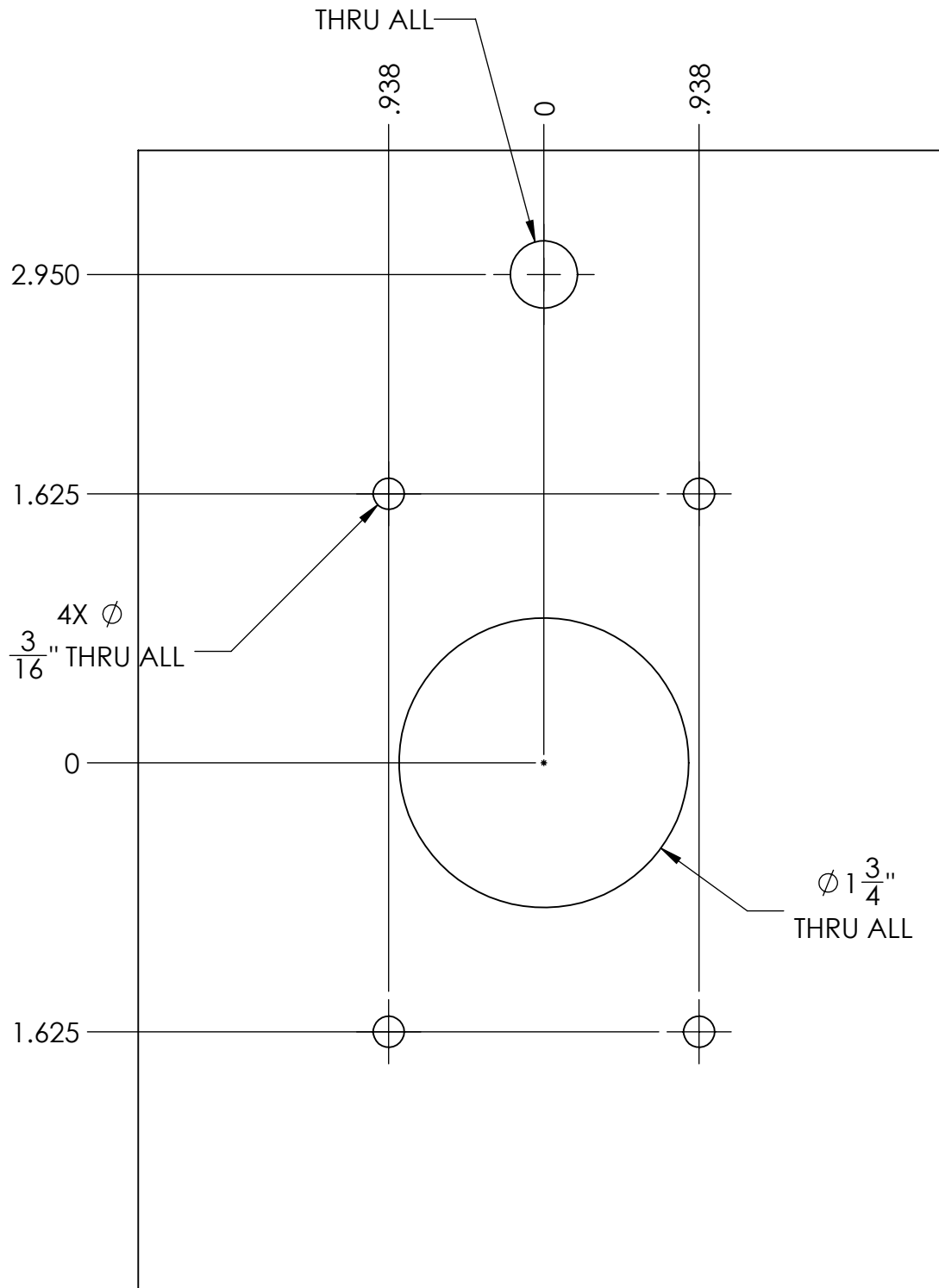

Figure 1: Hole Template

# INSTALLATION INSTRUCTIONS

## III. MOUNTING

1. Rubber gasket is premounted to the Deluxe Cover.
2. Install as shown in Figure 2: Cover and Gasket Mounting.
3. Insert (4) 8-32 X 7/8", PHILLIPS PANHEAD screws.

## IV. COVER & GASKET MOUNTING: Figure 2

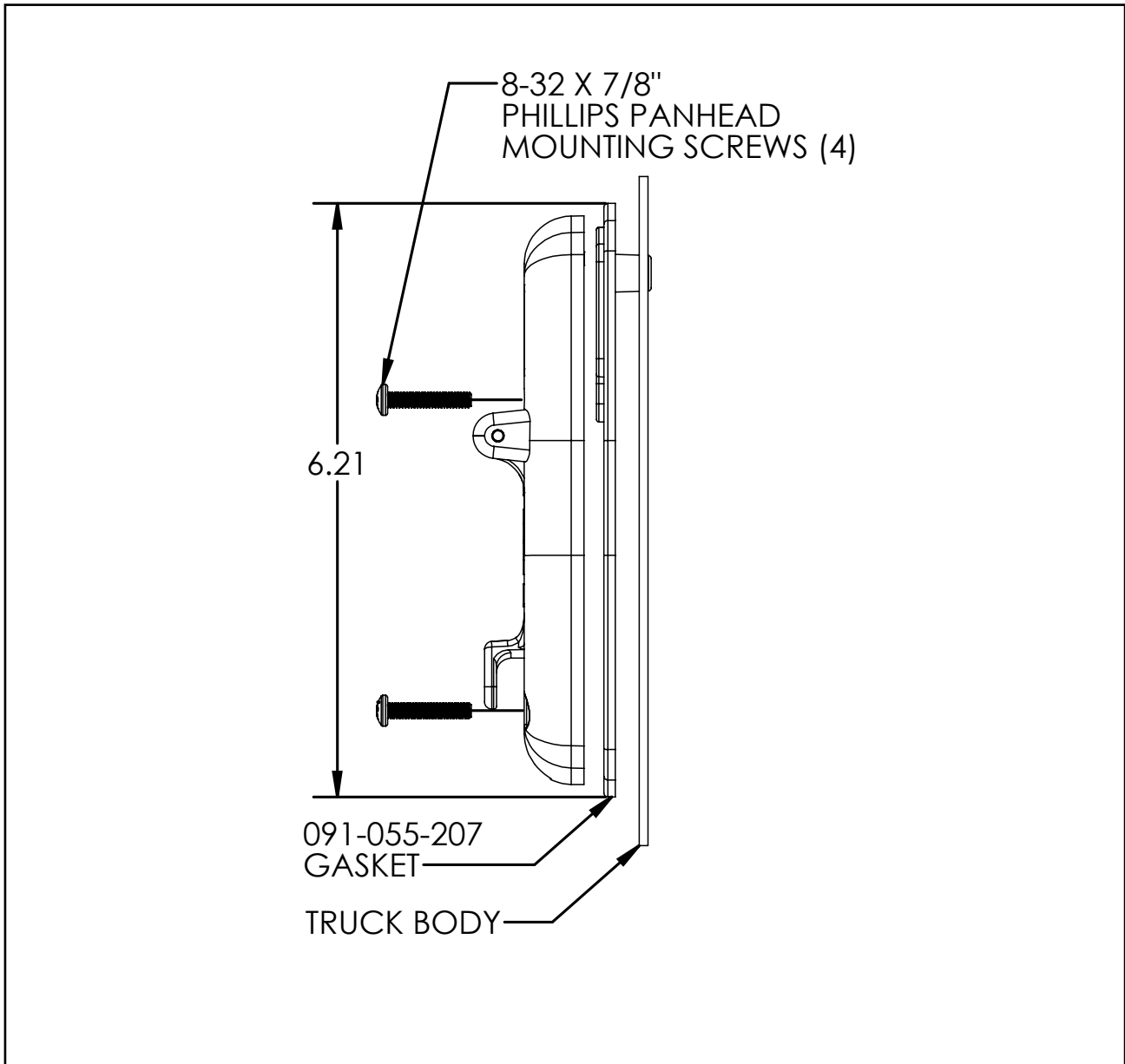

# WIRING DIAGRAM

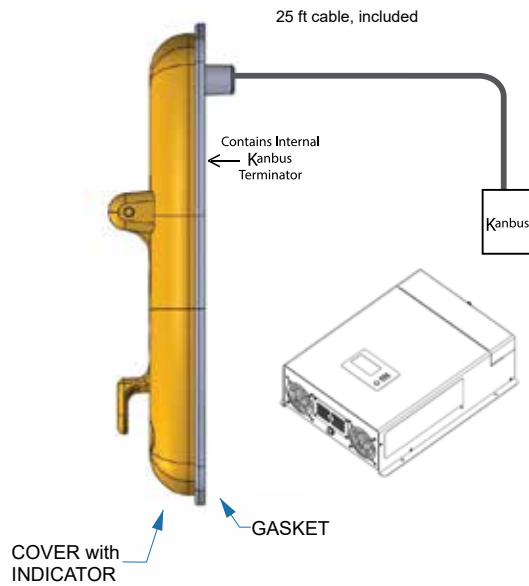

# OUTLINE DRAWING

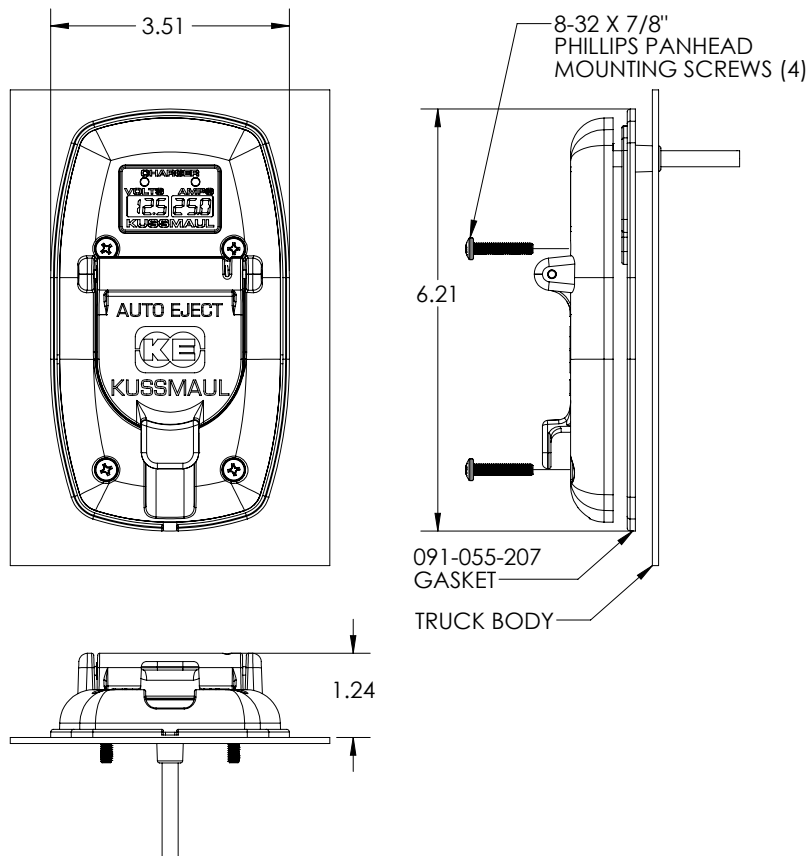

170 Cherry Avenue  
West Sayville, NY 11796  
www.kussmaul.com



Ph: 800-346-0857  
Fax: 631-567-5826  
sales@kussmaul.com

# SPECIFICATIONS

---

Interface: RS-232  
Input Current: 50mA,Max  
Temperature Range: -40F to 120F  
High Voltage: >14.8 VDC  
Charged: 13.15 - 14.8 VDC  
Charging: 13.1 - 12.3 VDC  
Low Voltage: <12.3 VDC  
Cord Type: RJ12  
Cord Length: 25 feet  
Warranty: 3 year

# INSTALLATION RECORD

---

DATE INSTALLED \_\_\_\_\_

INSTALLED BY \_\_\_\_\_

VEHICLE IDENTIFICATION \_\_\_\_\_

VEHICLE OWNER \_\_\_\_\_

# WARRANTY POLICY

---

All products of Kussmaul Electronics are warranted to be free of defects of material or workmanship. Liability is limited to repairing or replacing at our factory, without charge, any material or defects which become apparent in normal use within 2 years from the date the equipment was shipped. Equipment is to be returned, shipping charges prepaid and will be returned, after repair, shipping charges paid.

Kussmaul Electronics shall have no liability for damages of any kind to associated equipment arising from the installation and/or use of the Kussmaul Electronics products. The purchaser, by the acceptance of the equipment, assumes all liability for any damages which may result from its installation, use or misuse, by the purchaser, his or its employees or others.



Members of  
Fire and Emergency  
Manufacturers and  
Service Association



Members of  
National Fire  
Protection  
Association



Members of  
Fire Apparatus  
Manufacturers  
Association



170 Cherry Avenue  
West Sayville, NY 11796  
www.kussmaul.com



Ph: 800-346-0857  
Fax: 631-567-5826  
sales@kussmaul.com