

# **SUPER AUTO EJECT**

## **AUTOMATIC SHORE LINE DISCONNECT**



**MODEL # : 091-182-230-XX**

**CE marked for Low Voltage Directive 2014/35/EU**

File: 091-182-230-XX\_revB3  
Rev: B3  
Revised By: THN/PSS  
Date: 9-1-21

2 YEAR WARRANTY

---

170 Cherry Avenue  
West Sayville, NY 11796  
[www.kussmaul.com](http://www.kussmaul.com)

**KE KUSSMAUL™**  
**ELECTRONICS**  
*ENERGIZED AND READY, WHEN SECONDS COUNT*

Ph: 800-346-0857  
Fax: 631-567-5826  
[sales@kussmaul.com](mailto:sales@kussmaul.com)

# CAUTION

The **AUTO EJECT** must be connected to the starter circuit so that the solenoid is energized only while the engine is cranking. If the solenoid is energized continuously it will **OVERHEAT** and **BURN OUT**.

**FAILURE TO FOLLOW  
THIS CAUTION NOTE  
WILL VOID THE  
WARRANTY**

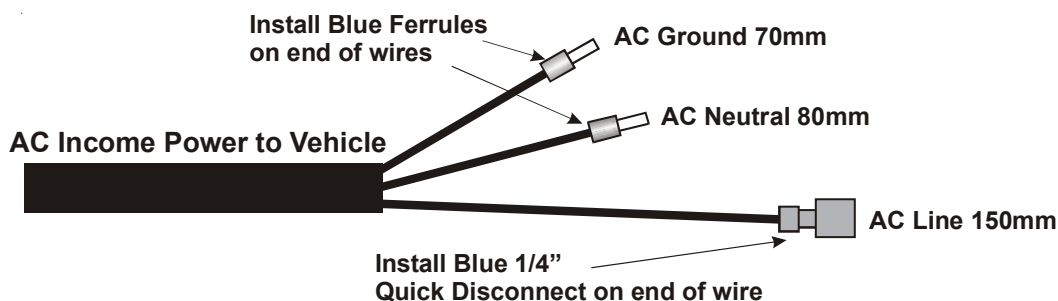
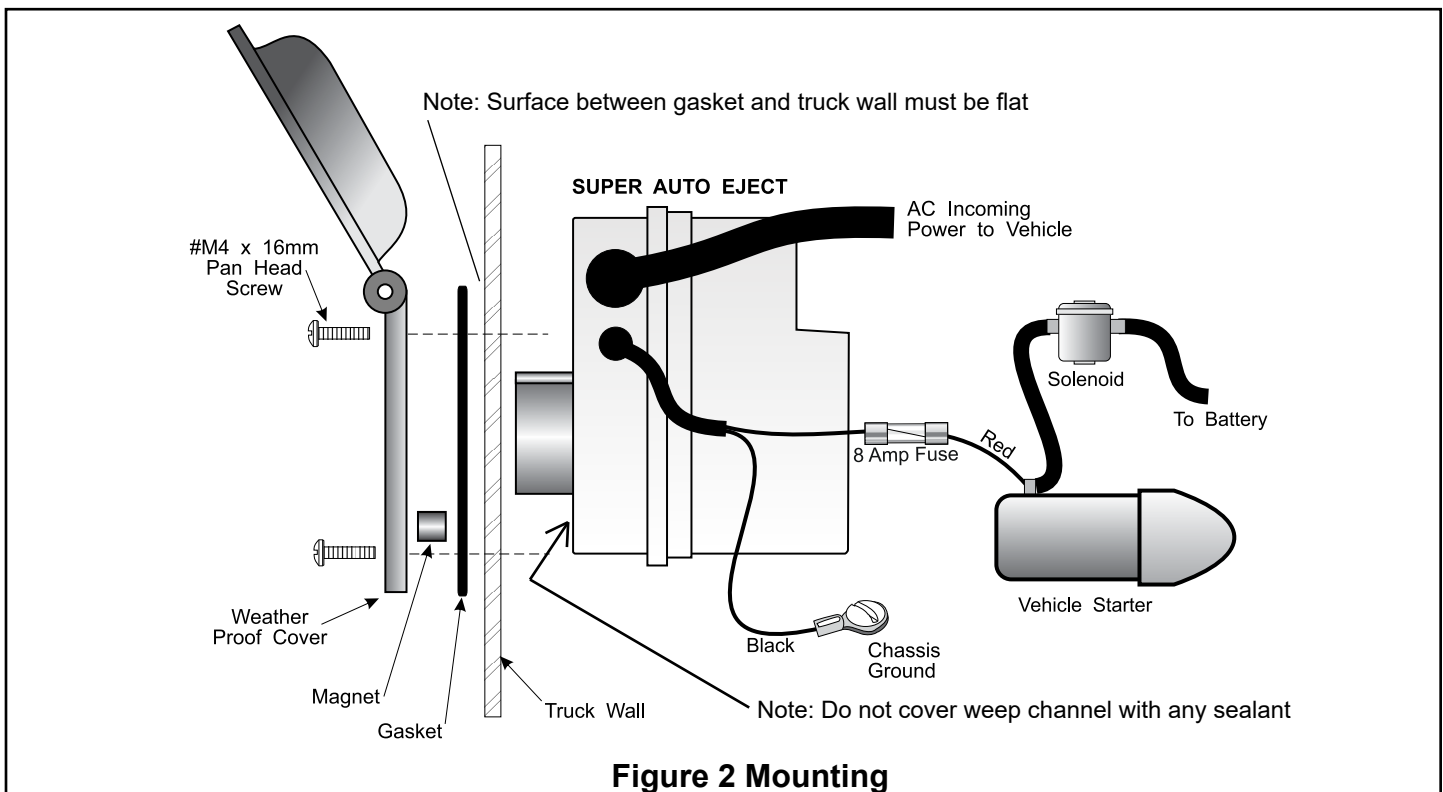

FIGURE 1 AC Wire Preparation

# INSTALLATION INSTRUCTIONS

1. Locate a convenient place on the vehicle to mount the AUTO EJECT. A minimum clearance of 4 5/8"(115mm) behind the mounting panel is required.
2. Place the Hole Template in position and center punch and drill in 6 places.
3. Mount the Auto Eject as shown in Figure 2.
4. Connect the DC wiring. Install the DC cable, use the 2 white connectors as shown in Figure 3. USE #16 GAUGE WIRE (up to 10ft), #14 (up to 15ft), #12 (up to 25ft).
5. Connect the AC wiring. Prepare the AC cable as shown in Figure 1. Then install the AC cable as shown in Figure 3. USE #14 GAUGE WIRE (up to 10ft), #12 (up to 15ft), #10 (up to 25ft).
6. Test installation by installing mating connector into the AUTO EJECT. Energizing the starter should energize the solenoid and eject the connector.
7. Keep connector and contacts of the AUTO EJECT clean. Lubricate contacts bi-annually with graphite petrolatum to insure free operation.

**Note: USE ONLY CORD CONNECTOR (PLUG) SUPPLIED WITH THE AUTO EJECT**  
**All connectors are not identical, using a substitute may result in unreliable operations or failure of the AUTO EJECT to operate**



# INSTALLATION INSTRUCTIONS

---

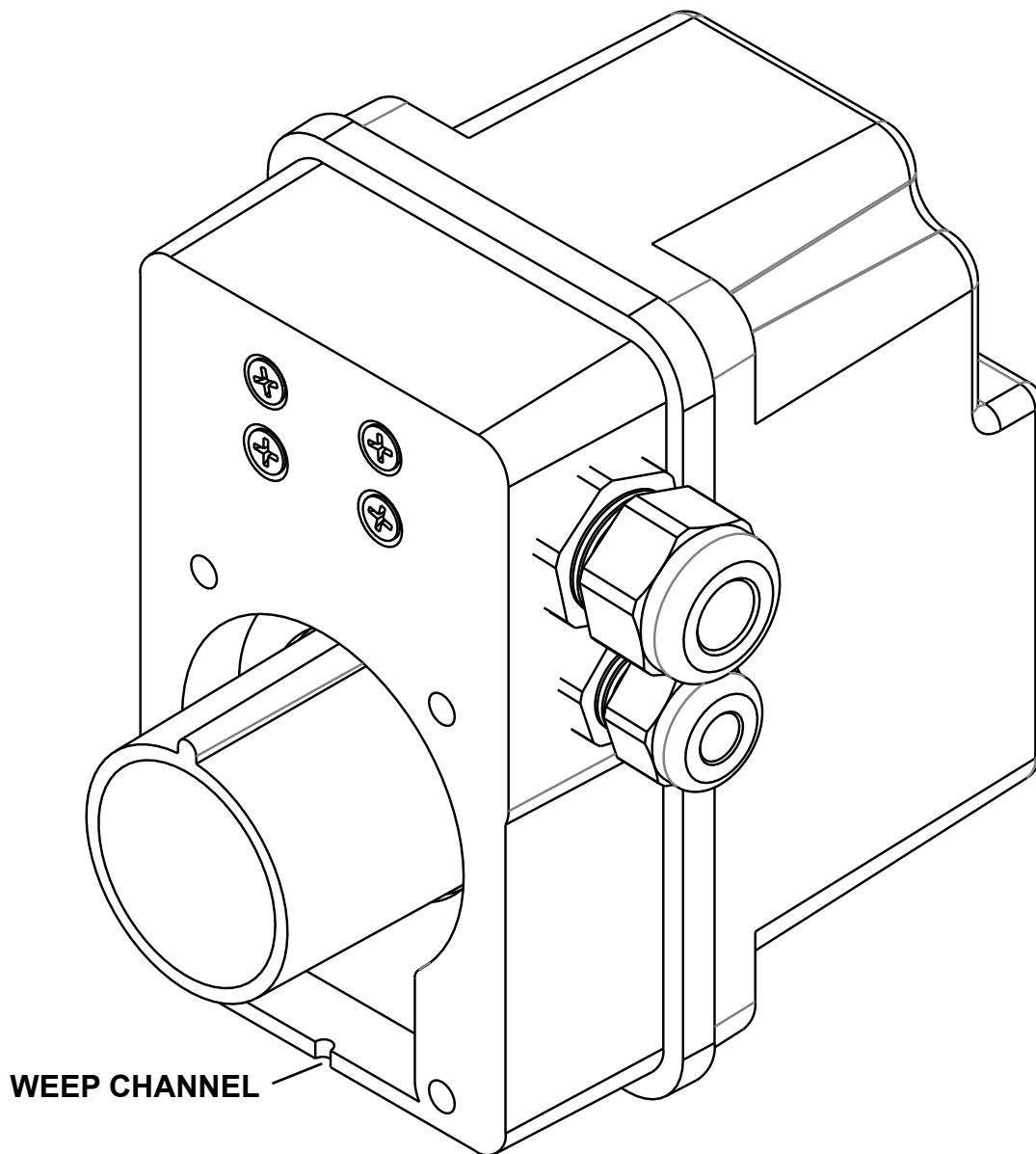

## IMPORTANT

**Do not cover the weep channel with any sealant. The weep channel allows drainage for any water that might accumulate.**

# WIRING DIAGRAM

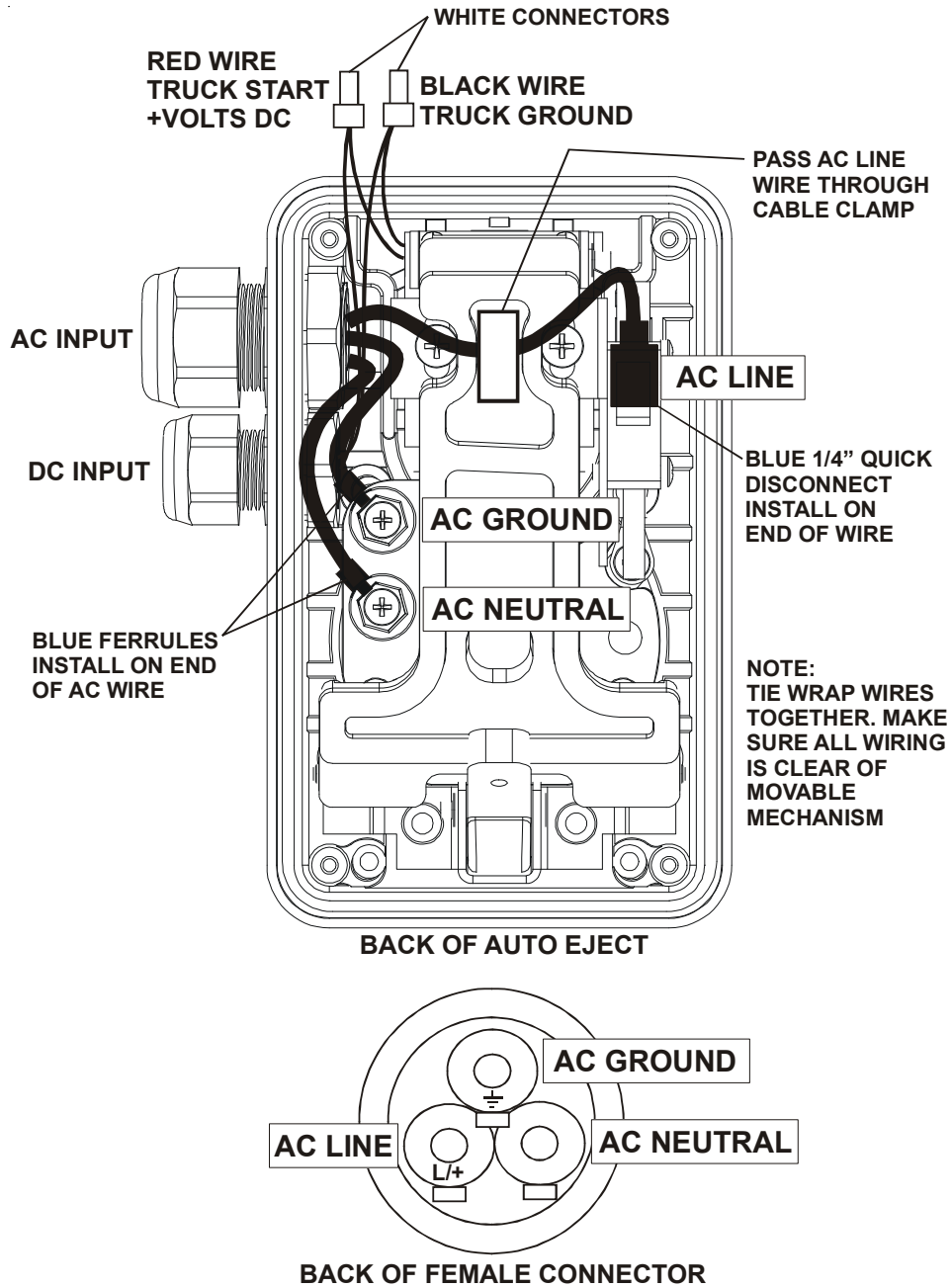
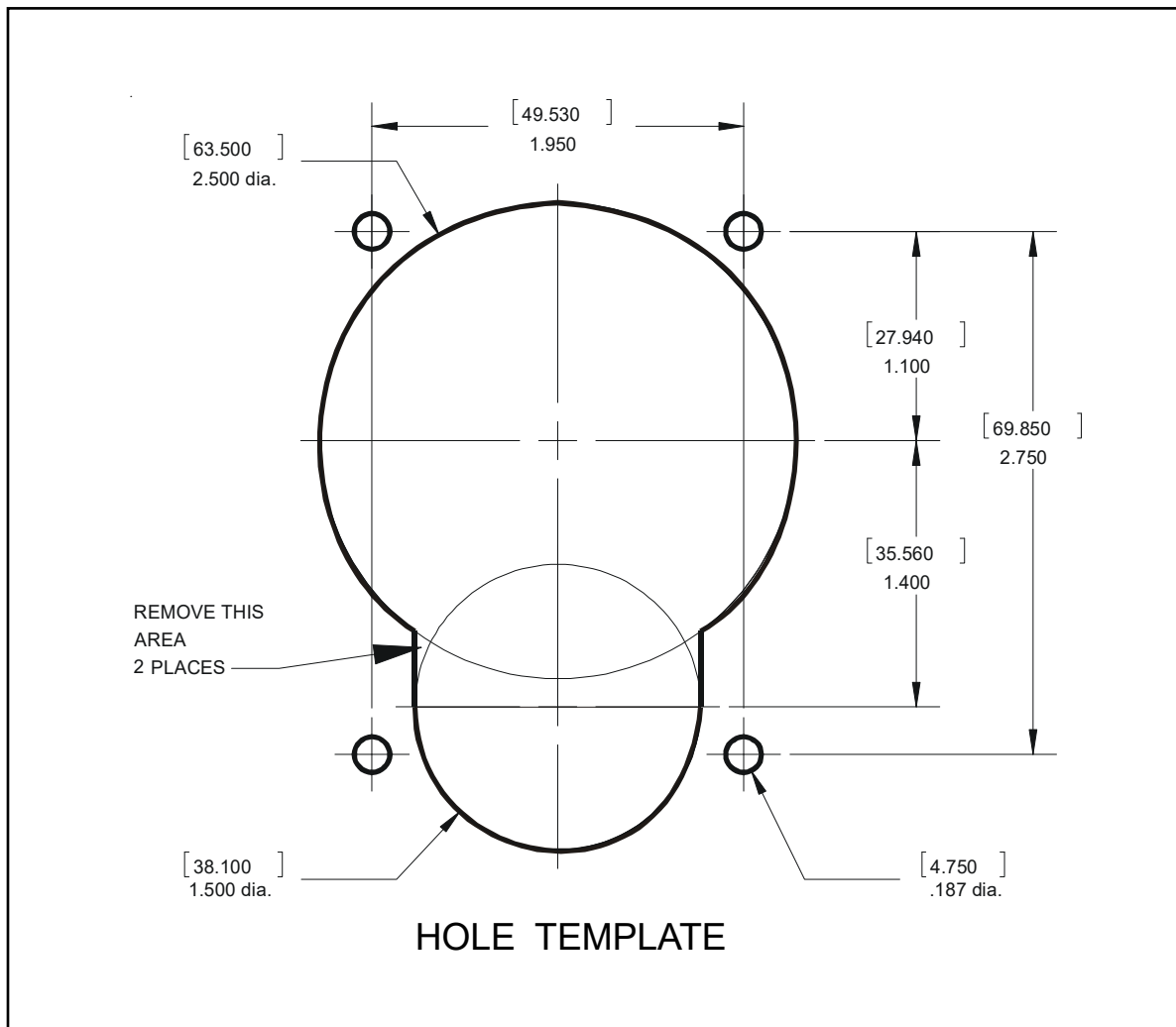

FIGURE 3 Wiring

# HOLE TEMPLATE



# SPECIFICATIONS

---

**Input Voltage:** 12V Nominal Model (10-16 VDC); 24V Nominal Model (20-32 VDC)

**Input Current:** 12V Model (6.7/10.7 Amperes Min/0Max); 24V Model (3.3/5.3 Amperes Min/Max)

**Electrical Rating:** 230 Volts AC, 16 Amperes Max

**Eject Signal Fuse:** 12V Model (8A Fuse), 24V Model (4A Fuse)

**Cover Mounting Torque Spec:** 100 in-oz

**IP Rating:** IP65 (cover closed); IP44 (cover open)

**Hardware Pack Provided:** cover with gasket and mounting screws, mating connector

**Weight:** 4 pounds

# INSTALLATION RECORD

---

DATE INSTALLED \_\_\_\_\_

INSTALLED BY \_\_\_\_\_

VEHICLE IDENTIFICATION \_\_\_\_\_

VEHICLE OWNER \_\_\_\_\_

# WARRANTY POLICY

---

All Auto Ejects manufactured by Kusssmaul Electronics Company Inc. are warranted to be free of defects of material or workmanship. Liability is limited to repairing or replacing at our factory, without charge, any material or defects which become apparent in normal use within 2 years from the date the equipment was shipped. Equipment is to be returned, shipping charges prepaid and will be returned, after repair, shipping charges paid.

This warranty does not include normal wear and tear, pitting of the electrical contacts, malfunction due to contamination of the mechanism, or solenoid overheating due to improper installation.

Kusssmaul Electronics Company, Inc. shall have no liability for damages of any kind to associated equipment arising from the installation and /or use of the Kusssmaul Electronics Company, Inc. products. The purchaser, by the acceptance of the equipment, assumes all liability for any damages which may result from its installation, use or misuse, by the purchaser, his or its employees or others



Members of  
Fire and Emergency  
Manufacturers and  
Service Association



Members of  
National Fire  
Protection  
Association



Members of  
Fire Apparatus  
Manufacturers  
Association



---

170 Cherry Avenue  
West Sayville, NY 11796  
www.kusssmaul.com



Ph: 800-346-0857  
Fax: 631-567-5826  
sales@kusssmaul.com