

END IDLING IN YOUR FLEET

SYSTEM BENEFITS:

- IMPROVE OPERATOR SAFETY
- ENGINE-OFF AIR CONDITIONING
- REDUCE OPERATING COST
- PROTECT THE ENVIRONMENT
- LIGHT WEIGHT
- SMALL FORM FACTOR

AC040N24-12K

The AC040N24-12K is a *Lithium-Iron powered A/C unit. This unit is utilized to provide operators with engine-off A/C. Not only does this product offer improved comfort, but it reduces the need to run the vehicle's engine to power the A/C system. This translates to reduced operating cost for your fleet and protects the environment.

This unit can be charged using 12V power from an alternator or solar panels. It may also be utilized as a stand-alone 110V A/C unit.

Note: This product requires other ZeroRPM IMS components. Reference ZeroRPM.com/systems for more information.

**"Lithium-Iron" is marketing term for ZeroRPM's LiFeMnPO4 packaged energy storage systems.*

SPECIFICATIONS:

Total Energy	1.02 kWh
Usable Energy	0.8 kWh
Nominal Voltage	12.8V
Battery Chemistry	Lithium-Iron (LiFeMnPO4)
Product Housing Material	Powder-coated Aluminum and Galvanneal
Weight	~70lbs / ~31.75kg
Charging Temperature Range	32°F to 150°F / 0°C to 65.6°C
Discharge Temperature Range	-4°F to 150°F / -20°C to 65.6°C
Cooling Capacity	~11,800 BTU (at target evaporator and condenser temp.)
Compatible Freon Types	R-1234YF or R134a
A/C Fitting Sizes	#8-MIO Pressure / #10-MIO Suction
System Protection Fuse	100A (external to unit)
Input Voltage Range	12.2V-15.2V
Nominal Current Consumption	65A
Max Current Consumption	85A
Internal Fuse Rating	100A

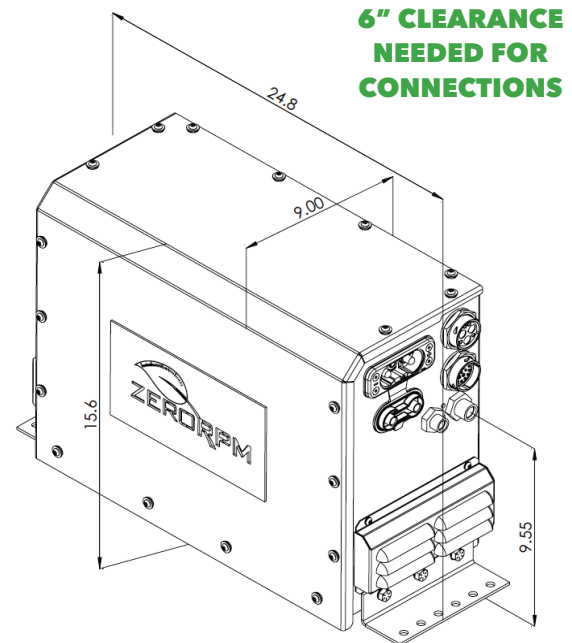

*Temperatures are based on software versions 4.94.00 and later with battery SOC of >40%.

Ask for ZeroRPM[®] Idle Mitigation Systems[®] WHERE you purchase your fleet vehicles

AC040N24-12K ALL DIMENSIONS ARE IN INCHES

**FOR WIRING OF THE SYSTEM
PLEASE REFERENCE THE
SYSTEM SCHEMATIC**

**6" CLEARANCE
NEEDED FOR
CONNECTIONS**

**SIGNAL
CONNECTIONS**



**47 PIN
PRODUCT
INTERFACE
CONNECTOR**

**POWER
CONNECTIONS**



**12V POWER
2-CABLE
REBLING
CONNECTOR**

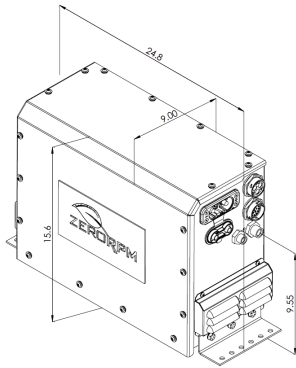

FRONT

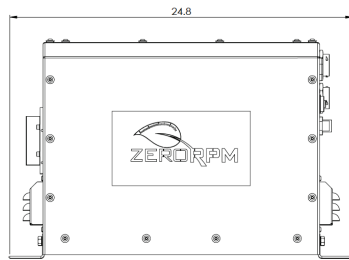

TOP

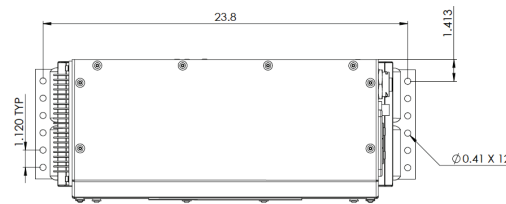

SIDE

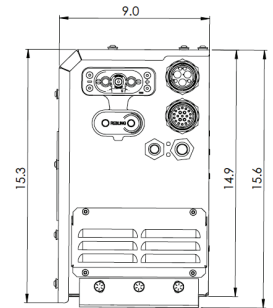

PRODUCT NOTES:

- Storage temperature: -4 °F to 149 °F / -20 °C to 65 °C.
- The unit must be mounted securely and upright.
- In shipping or storage, do not stack more than one product on top of one another (i.e. two unit stack maximum).
- The unit must be mounted so the lid is removable.
- The unit must be mounted as closely to the loads and supply as possible.
- If the unit has been in storage for more than 90 days, the voltage must be checked to ensure that the batteries have not discharged past the acceptable threshold.
- There must be adequate provisions for drainage below the unit to prevent flooding.
- There must be at least 6" of clearance on the right side of the unit for the main power connectors and/or A/C lines.
- Wash-down requirements: Do not pressure-wash the unit below 10° (horizontal) into the vents. Do not pressure-wash any closer than 12" from the unit.
- The A/C lines must not be left uncapped longer than 15 minutes.
- The unit must be mounted in a well-ventilated compartment. In extreme hot or cold environments, it is ideal to mount the unit in a temperature controlled compartment.
- The unit can operate up to a 45° angle from vertical orientation.
- The unit must be mounted with vibration-dampening material. The material must be installed between the unit's feet and the mounting surface.
- Exporting at maximum current for an extended amount of time will substantially reduce the life of the battery pack.
- To ensure proper air flow, the filter on the unit should be cleaned every 6 months in external or unfiltered environments. Filter should be cleaned annually, or as specified by internal procedures, if in a filtered environment.
- Do not run the IMS without charging the A/C system.
- Do not put the unit on its side or upside down without written approval from ZeroRPM.
- Do not extend the current shunt wires (if current shunt wires are present).
- Excessive oil in the A/C circuit could harm the A/C system and reduce performance.
- Use only PVE oil in the A/C circuit of the system.