

THEORY OF NAV-PAC OPERATION

NOISE FILTER / VOLTAGE TRANSIENT PROTECTOR WITH BATTERY BACK-UP

The NAV-PAC is wired in series with the DC power to sensitive electronics and:

- (1) Filters out noise interference on incoming power lines.
- (2) Clamps voltage spikes and transients to a safe level.
- (3) Provides battery back-up power during voltage drops due to starter motors and momentary losses of power.

SPECIFICATIONS

- INPUT:** 12 VDC, Nominal Charging:13.8-14.4 VDC,
To Prevent Discharge:13.4 -14.4 VDC, Maximum: 15.5 VDC
- OUTPUT:** Filtered, Voltage Spike Protected With Back-Up Battery 20 amps Max.
- BACK-UP POWER:** 12.0 VDC Nominal
5.0 AH Capacity
7 amps for Fifteen (15) Minutes
10 amps for Eight (8) Minutes
15 amps for Two (2) Minutes
20 amps for One (1) Minute
- BATTERY:** Sealed Rechargeable 5.0 AH, 5-7 Years Typical Life - Replaceable
- FILTERING:** Audio Through 200 MHz
- VOLTAGE SPIKE PROTECTION:**
Transient Energy Capability; 100 Joules, 4,000 amps Max
- OPERATING TEMPERATURE:** 0-50°C

SIZE-WEIGHT	H	W	D	
	5.25"	6.2"	7.4"	5.2 lbs.

M-NAV-PAC-G 13.3 (cm) 15.7 (cm) 18.8 (cm) 2.4 kg

AS OF November 2009

NAV PAC™

INSTALLATION AND OPERATION MANUAL



NEWMAR®
DC Power Onboard™
www.newmarpower.com

P.O. Box 1306 • Newport Beach, CA 92663
Shipping: 2911 W. Garry Ave. • Santa Ana, CA 92704

Phone: (714) 751-0488

Fax: (714) 957-1621

e-mail: sales@newmarpower.com

www.newmarpower.com

TABLE OF CONTENTS

FEATURES	2
GENERAL INFORMATION	3
Voltage Spike Protection	
RF Noise Filtering	
Back-Up Power	
Warning of Imminent Loss of Power	
Timed Disconnect Circuit	
Low Battery Disconnect Circuit	
MATERIALS PROVIDED	4
INSTALLATION	4
Main Unit	
Remote Panel	
OPERATION	5
BATTERY CHARGING/REPLACEMENT	6
TEST/TROUBLESHOOTING	7
THEORY OF OPERATION	8
SPECIFICATIONS	8

FEATURES

- Back-Up Battery maintains DC output voltage during dips and black-outs — prevents memory loss and system crashing in GPS, MDTs, and other critical electronics.
- Multi-Stage Filter eliminates electronic noise and interferences, providing pure power navigation electronics require.
- Power Status Panel alerts operator to possible loss of power.
- Overvoltage transient protection prevents damage to sensitive circuitry due to voltage line spikes.
- Low voltage and timed disconnect circuits protect internal battery against shortened life or damage due to excessive discharge.
- Maintenance-free solid state circuitry assures years of dependable service.
- Conformal coated printed circuit board resists corrosion.
- Rugged, rust and corrosion-proof vinyl laminated aluminum case provides protection for components.
- All components selected for dependable performance in the most hostile environments.
- Each unit thoroughly tested and inspected before shipment.
- Two year limited warranty.

GENERAL INFORMATION

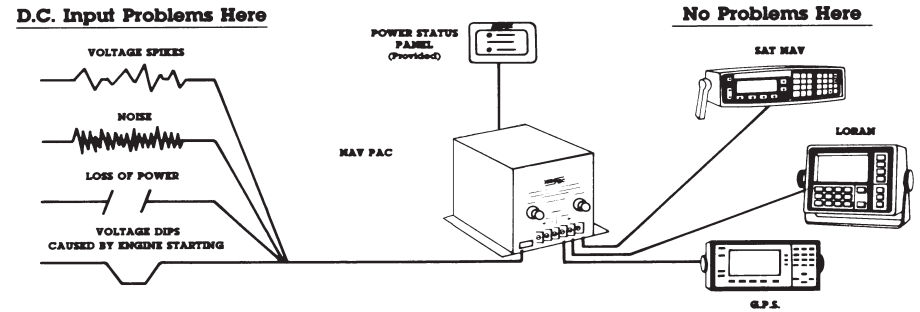

The NAV-PAC protects electronics from voltage spikes, power surges, momentary power losses, abrupt voltage changes and noise interference on incoming DC power to MDTs, GPS, CHART PLOTTERS and other Onboard Electronics prone to memory loss or “crashes”.

NAV-PAC is a solid state device which provides “pure” power to navigation electronics by performing several essential functions.

- 1) **Voltage Spike Protection:** Engine cranking, pump and motor operation send voltage “spikes” through a boat’s electrical system that often “bulldoze” their way through the electronic circuitry. NAV-PAC eliminates this ruinous condition.
- 2) **R.F. Noise Filtering:** The NEWMAR NAV-PAC contains a four-element low-pass LC filter which provides very high radio frequency attenuation in both positive and negative power leads to the receiver preventing noise from adversely affecting signal reception and related operation.
- 3) **Back-Up Power:** A special long-life, completely sealed “Dry Battery” pack is built-in the NAV-PAC which acts a power reservoir and is charged from the shipboard 12 Volt power. In the event of a drop in DC voltage due to engine cranking or total power interruption, the battery will maintain power to navigation equipment for a short period of time. This is essential for preventing memory and data loss.
- 4) **Warning of Imminent Loss of Power:** A remote panel is supplied with the NAV-PAC and its function is very important; it warns of loss of input power and indicates output is available to your navigation equipment. A flashing “Out put OK” indicator light warns the operator that the NAV-PAC has lost DC input and that the navigation equipment is being powered by the NAV-PAC’s internal battery only.
This allows the user time to restore DC input to the NAV-PAC and navigation equipment or to turn off the navigation equipment before the input voltage drops, causing memory loss.
- 5) **Timed Disconnect Circuit:** This circuit prevents damage to the internal battery from extreme discharge by disconnecting the NAV-PAC battery approximately 15 minutes after abrupt drop or complete loss of DC input.
- 6) **Low Battery Disconnect Circuit:** This circuit prevents damage to the internal battery from extreme discharge by disconnecting the battery whenever battery voltage reaches 10.2 VDC.

MATERIALS PROVIDED

Your NAV-PAC comes with the following materials:

- (3) # 8 ring lugs for 22-16 gauge wire
- (4) # 8 ring lugs for 12-10 gauge wire
- (3) butt connectors
- (1) Installation/Operation Manual

Check to see that these have been included with the packaging. For any missing items, please contact the factory.

INSTALLATION

- After you have determined the best location in the system, locate a flat surface close to the power line that feeds the GPS, SAT-NAV or plotter. For best results the NAV-PAC unit should be within 24" of the critical electronics. The case need not be grounded, so it is acceptable to mount the unit on wood or metal. Securely mount the NAV-PAC.

Turn off power to the wires that will be cut or worked on by disconnecting the battery or shutting off the appropriate circuit. Identify the positive and negative lead in the power line and cut at an appropriate location. Use the lugs supplied to hook up the NAV-PAC to your system.

- Using the table below, select the proper wire size for your installation:

AMPS *	CABLE LENGTH (feet)		
	10'	15'	20'
0 - 10 AMPS	14 AWG	12 AWG	12 AWG
10 - 20 AMPS	10 AWG	10 AWG	10 AWG

*Current draw of NAV equipment being powered.

Replace terminal block cover to prevent accidental shorting of the terminals.

Important Installation Note: If there is to be a continuous load on the Nav-Pac output during normal operation, the DC input must be a minimum of 13.4 VDC to prevent discharge of the internal battery.

TYPICAL INSTALLATION DIAGRAM

NOTE: Remove both fuses before wiring the NAV-PAC. Reinstall fuses only after carefully checking installation and wiring.

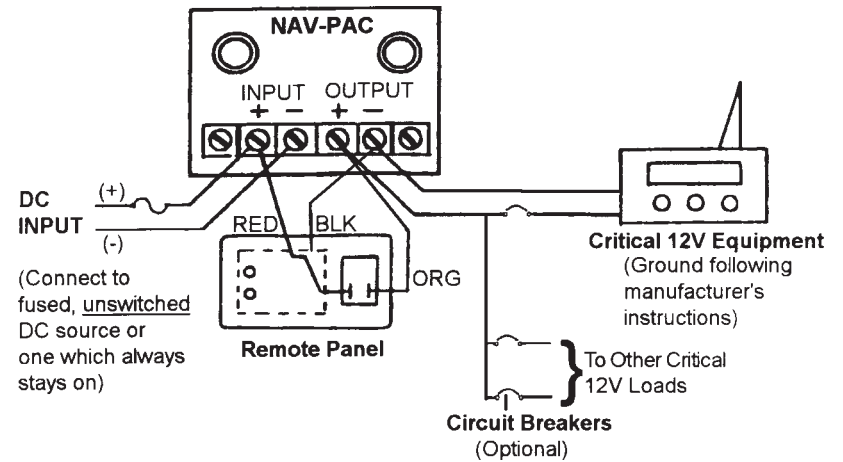

- Remote Panel: Mount in a conspicuous location where the loss of power indication will be noticed. The NAV-PAC will function normally without the remote panel or with the remote panel switch off. Connect the wiring as follows: (see diagram)

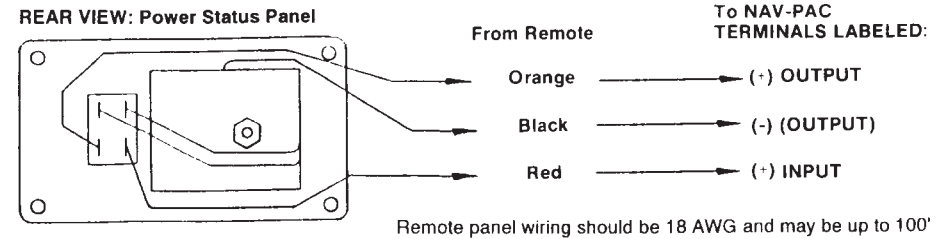

OPERATION

When the remote status panel is properly hooked up and DC power is being applied to the NAV-PAC, both the "INPUT OK" and "OUTPUT OK" LED's will steadily illuminate. This indicates that pure DC power is available at the output terminals and that the internal 5.0 amp-hour battery is being kept charged. (The LED lights draw only about .01 amp each.)

In the event of a loss of DC input to the NAV-PAC, the "INPUT OK" LED will be extinguished and the "OUTPUT OK" LED will begin to flash. This indicates that the navigation equipment is being powered by the NAV-PAC's internal battery only. It will also indicate that the timed battery disconnect circuit has been initiated. After approximately 15 minutes the NAV-PAC's internal battery will automatically disconnect from the NAV-PAC's output. This is to protect the battery discharge if

the input is switched off. To reset this circuit input to the NAV-PAC must be restored.

Bear in mind that the NAV-PAC has another disconnect circuit which may cause it to shut down sooner. The battery is also protected by a low-voltage disconnect circuit. Should the current draw of the device being powered cause the battery voltage to drop to 10.2 VDC before 15 minutes have passed, then this circuit will disconnect the battery from the output. The amount of time the equipment will continue to function normally before the NAV-PAC will shut down will depend, in this case, upon the current draw of the device being powered. (See BACK-UP POWER in the **SPECIFICATIONS** section on page 8.) To reset this circuit, the internal battery must be recharged. Reduce or shut off the electronic load, and insure that an adequate charge voltage is restored to the input. (See **BATTERY CHARGING/REPLACEMENT.**)

If you are unable to restore DC power immediately it is probably a good idea to turn off the equipment being powered by the NAV-PAC. Most communication or navigation equipment with built-in memory has a "keep alive" or "soft" shutdown that is activated by the on/off switch. But if the input voltage is slowly reduced, as will occur when the NAV-PAC battery discharges, this "keep alive" feature may not activate, resulting in loss of memory, waypoints, etc.

REMEMBER: When you wish to shut off your com/nav equipment, you must shut it off with the power switch to the equipment itself. *Do not shut off the input to the NAV-PAC.* The NAV-PAC will simply treat this the same as an emergency loss of DC input, and will continue to supply the comm/nav equipment with DC power from its internal battery until auto-shutdown occurs.

If you are not powering equipment with the NAV-PAC and it is not being supplied with DC input, it is recommended that you turn off the remote panel. Though the current draw from the LED's is slight, it will unnecessarily drain the battery over time if they are left on.

BATTERY CHARGING/REPLACEMENT:

CAUTION: DO NOT LEAVE THE BATTERY DISCHARGED FOR EXTENDED PERIODS OF TIME. IT MAY BE PERMANENTLY DAMAGED AND MAY NOT TAKE A RECHARGE.

The battery requires no maintenance and is completely sealed. Battery life is up to five years. To charge the battery requires an input voltage of 13.8 to 14.8 VDC for 3-4 hours or more per month. To prevent discharging requires a nominal input of 13.4 - 14.4 VDC. These voltages are normally produced by an engine alternator or good quality battery charger.

The battery storage time @ 23°C is 400 days. The battery should be replaced no less frequently than every five (5) years to guarantee proper operation of the NAV-PAC. (Request part #425-1204-0)

To determine the age of the battery in your NAV-PAC, check the quality control sticker on the end of the unit. The first four digits of the serial number (designated "S/N") refer to the year and month of manufacture. For instance, a unit with a serial

number starting "0435" was manufactured the 35th week of 2004, Be sure to mark the date of replacement on this sticker for future reference.

BATTERY REPLACEMENT PROCEEDS AS FOLLOWS:

Caution: Take care to ensure that you do not short the battery terminals during installation. The resulting high current can melt wires and cause other damage to the unit.

1. Turn off power to the input wiring and disconnect all input and output connections to the NAV-PAC. Remove the unit from the mounting surface.
2. Remove the fuse from the fuseholder labeled "BATTERY" on the front panel.
3. Remove the four screws on the top of the unit and the four screws on either side of the unit.
4. Remove the cover.
5. Disconnect the battery terminals.
6. Remove the four screw / washer sets that are securing the battery hold-down bracket.
7. Slide the battery and bracket out from under the PCB.
8. Slide the new battery and bracket into the NAV-PAC and reverse all above procedures.

Dispose of the old battery properly and according to local codes. Although the battery is sealed, it is a lead-acid type and there may be restrictions on its disposal.

TEST / TROUBLESHOOTING

To test the battery operation, disconnect the input power at the source or remove the input fuse, and, using a voltmeter, note that DC output power is still present on the output terminals. Note that after approximately 12-15 minutes the output will disconnect automatically to protect the internal battery. You should then measure no voltage on the output terminals. To reset this timed circuit, reconnect the NAV-PAC input to the ship's battery.

The noise filtering and spike protection circuitry won't require testing unless the NAV-PAC blows fuses repeatedly, or has had a nearby lightning strike, or other very high energy transient.

If the NAV-PAC blow fuses repeatedly (replace with 20 Amp Fast Acting Fuse: ABC-20 or AGC-20), this usually indicates a shorted component. Have a qualified technician perform the repairs or return the unit to NEWMAR for factory inspection.

Always verify that the replaced fuses are of the correct rating. Use standard AGC or fast-blow fuses. Do not use slow-blow fuses.