

INSTRUCTION MANUAL

AUTO ISOLATOR 3

AN AUTOMATIC LOSSLESS BATTERY ISOLATOR
FOR 3 BATTERY SYSTEMS



MODEL # 091-208-3-12

BATTERY VOLTAGE: 12 VDC
OUTPUT: 12 VOLTS, 3 AMPS

BATTERY PARALLELING SOLENOID: 200 AMPS

3 YEAR WARRANTY

170 Cherry Ave
West Sayville NY 11796
www.kussmaul.com

KE KUSSMAUL™
ELECTRONICS
ENERGIZED AND READY, WHEN SECONDS COUNT

Ph: 800-346-0857
Fax: 631-567-5826
sales@kussmaul.com

INTRODUCTION

The Model 091-208-3-12 AUTO ISOLATOR 3 system is a lossless isolator replacement for the conventional diode isolator. Designed to be installed in a vehicle with an three battery system that must be isolated from each other. The system consists of a voltage detector controller Model 091-208-12 and two separate 200-ampere rated solenoid, Model 091-139-SOL-12HO for switching the batteries.

SYSTEM OPERATION

The system receives its power from the Battery 1 input or it can be switched on/off. With the switch "OFF" all the power is removed from the system and the solenoids are deenergized. As soon as any of the 3 batteries go above 13.2 volts all 3 batteries are paralleled by the solenoids being energized thus charging all 3 batteries. When the battery voltage of the 3 connected batteries go below 12.6 volts all 3 batteries are disconnected by the solenoids being deenergized and will be reconnected when the battery voltage rises above 13.2 volts.

INSTALLATION

Install the 091-208-12 Controller in a suitable location protected from the weather and engine heat. The Solenoids may be mounted in the engine compartment or at a location to minimize the length of the battery cables.

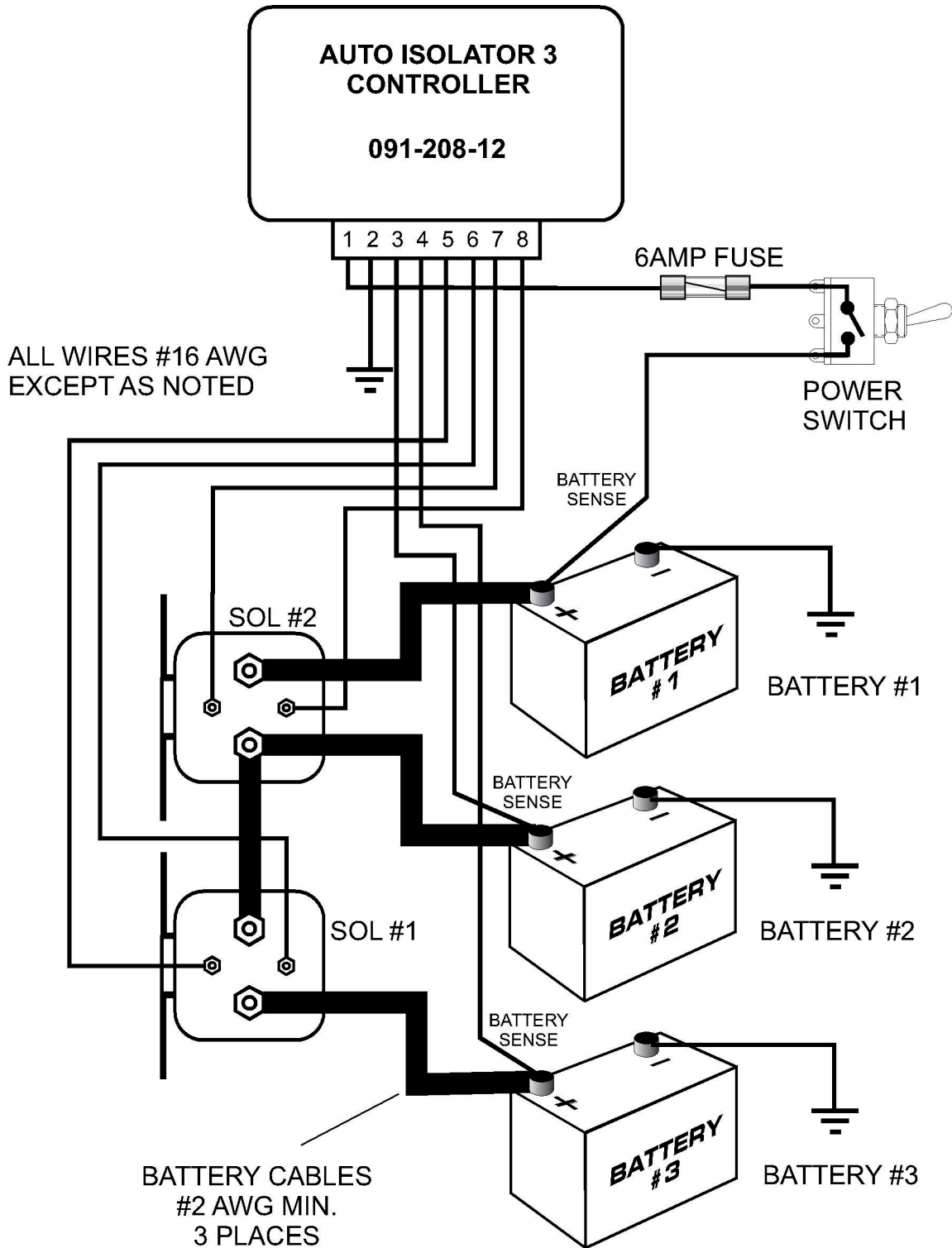

SPECIFICATION AND OUTLINE

CONTROLLER, Model 091-208-12

Volts to parallel, normal operation: 13.2 volts
Hysteresis 0.60 volts (13.2 volts on - 12.6 volts off)
Battery load: .020 amps.
Output current: 3 amps
Weight: .4 lbs.

SOLENOID, Model 091-139-SOL-12HO

Volts: 12 volts D.C.
Coil current: .45 amps

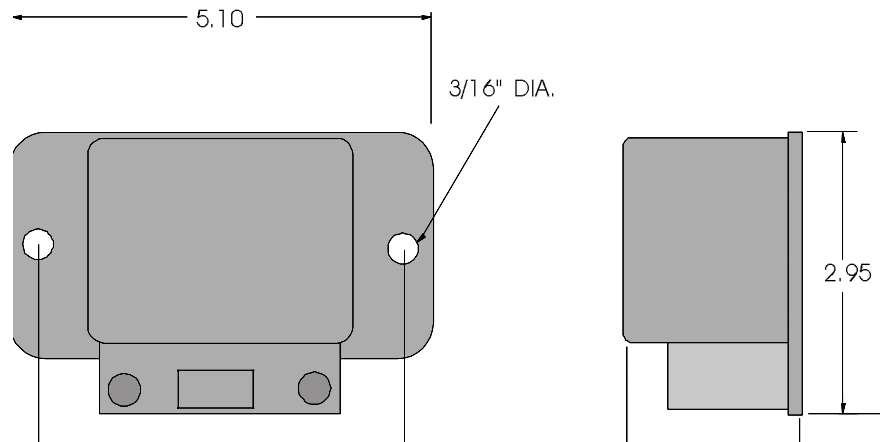

OUTLINE, AUTO ISOLATOR I CONTROLLER, 091-208-12

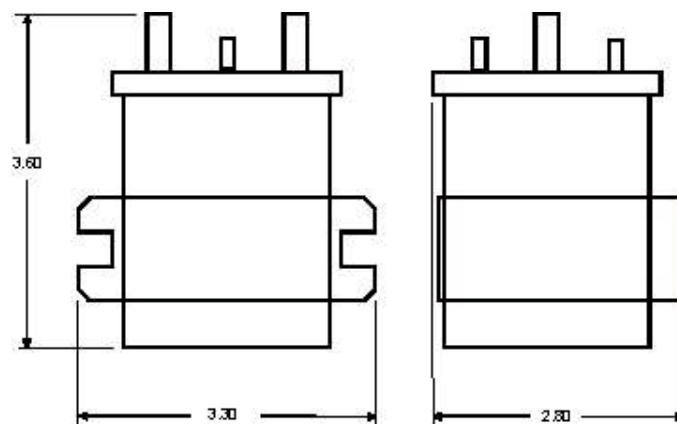

OUTLINE, AUTO ISOLATOR I SOLENOID, 091-139-SOL-12HO

INSTALLATION RECORD & WARRANTY

Date Installed _____

Installed By _____

Vehicle Identification _____

Vehicle Owner _____

WARRANTY

All product of Kussmaul Electronics Company Inc. are warranted to be free of defects of material or workmanship. Liability is limited to repairing or replacing at our factory, without charge, any material or defects which become apparent in normal use within 3 years from the date the equipment was shipped.

Kussmaul Electronics Company, Inc. shall have no liability for damages of any kind to associated equipment arising from the installation and /or use of the Kussmaul Electronics Company, Inc. products. The purchaser, by the acceptance of the equipment, assumes all liability for any damages which may result from its installation, use or misuse, by the purchaser, his or its employees others.