

# SUPER 30 AUTO EJECT -AE

**AUTOMATIC AIR-ELECTRIC SHORELINE DISCONNECT**



**MODEL # : 091-169-30-250**

**30 Amps Max, 250 Volt Max, 175 PSI Max**

File: IM\_091-169-30-250\_reva.indd  
Rev: B  
Revised By: THN  
Date: 10-21-2013

2 YEAR WARRANTY



scan using your mobile  
device for more information

170 Cherry Avenue  
West Sayville, NY 11796  
www.kussmaul.com

**KE KUSSMAUL™**  
**ELECTRONICS**  
ENERGIZED AND READY, WHEN SECONDS COUNT

Ph: 800-346-0857  
Fax: 631-567-5826  
sales@kussmaul.com

# INTRODUCTION

---

The Super 30 Auto Eject -AE, adds an air pressure connection to the popular Super 30 Auto Eject. Thus, in one connection the vehicle is supplied with 30 amperes of electric power and an air pressure line to recharge the vehicles air brake reservoirs. A standard 4 pin connector is modified to replace one of the electrical pins with a specially designed air connection. The Air-Electric connector is part number 091-169-CON-4P-250. The Air-Electric connector contains a shut-off valve that is opened when the connector is mated with the Auto Eject. The valve closes when the plug is ejected and retains the supply air. A novel plug detector closes and opens the A.C voltage circuit after the mating connector is inserted and before the connector is ejected. This eliminates arcing at the connector contacts and assures long contact life.

As with all Auto Ejects the Super 30 Auto Eject -AE is connected to the starter circuit so that ejection occurs when the engine is cranked.

## INSTALLATION INSTRUCTIONS

---

### I. WIRING AND PLUMBING THE SUPER 30 AUTO EJECT -AE

1. Remove rear plastic cover from the Auto Eject by unscrewing (4) #8-32 screws
2. See Figure 3, D.C. wiring. Snake wires through small strain relief and install wires as shown using #18 AWG wire minimum.
3. See Figure 2, A.C. wiring. Snake wires through large strain relief and install wires, #10 AWG minimum, as shown.
4. Install tubing to air outlet fitting on side of Auto Eject. The other end of this tubing is to be connected to the vehicle's air tank see figure 10.
5. Reinstall the rear plastic cover and tight screws to 4 in/lbs
6. Test the unit to see if it is operational before mounting

### II. MOUNTING THE SUPER 30 AUTO EJECT -AE

1. Locate a convenient place on the vehicle to mount the Auto Eject. A minimum clearance of 5 inches behind the mounting panel is required.
2. Place the hole template (Figure 4) in position and center punch in 6 places. **\*Note:** it is recommended to mount the unit vertically with the weatherproof cover closet to the top of the mounting plate (see Figure 1).
3. Drill 6 mounting holes, #29 drill (0.136" diameter). Be certain that all the holes are precisely located.
4. Cut-out rectangular hole.
5. See figure 1 mounting. Install weatherproof cover, weatherproof cover gasket, mounting plate, and mounting plate gasket to Auto Eject using (2) #8-32 x 3/4" and (2) #8-32 x 1 5/8" screws provided.
6. Install the assembly into the cut-out in the truck wall using (6) #8-32 x 1/2" self tapping screws provided.

### III. WIRING AND PLUMBING THE MATING CONNECTOR

1. Insert AC power cable and 5/32"(4mm) air tubing though the back end of connector see figure 5
2. Connect AC power cable and 5/32"(4mm) air tubing to connector see figure 6
3. Mate the front and back of the connector and lock together. **CAUTION** Do not crimp Air Tubing with locking wings when tightening locking ring see figure 7.
4. Use the Flex Guard sleeving to secure the air tubing to the AC power cable see figure 8. Use a small piece of PVC tape to prevent the sleeving from fraying at the back end of the connector see fig 9.
5. Plumb the connector to an air source. We recommend using an air filter and shut of valve for maintenance of the system.

## TEST AND OPERATION

---

### I. ELECTRICAL TEST

Inspect and verify that the D.C. wiring is properly connected to the terminal strip as illustrated in figure 3. Measure the D.C. voltage from pin 1 to pin 2. This voltage should equal the battery Voltage of the vehicle. Now measure the voltage from pin 3 to pin 2 and crank the engine. Cranking the engine should create a D.C. voltage from pin 3 to pin 2 approximately equal to the battery voltage and simultaneously cause the plug to eject.

### II. PNEUMATIC TEST

Verify that the air supply is providing air pressure to the shoreline connector. Depress the air valve actuator pin in the air pin of the connector using a small screw driver being careful not to damage or bend the bin. When this pin is depressed air should flow and flow cease when the screw driver is removed.

### III. OPERATION

Install the connector in the Super 30 Auto Eject -AE and note that air flows to fill the vehicle's air tank and A.C. power is applied to the vehicle mounted battery charger. Verify that cranking the engine ejects the shoreline.

# NOTES AND CAUTIONS

---

## I. NOTES

Do not permit the shore line to drop to the floor when it is ejected. Keep from falling by utilizing a bungee cord restraint, cord reel or some other device. Dropping the connector may result in damage or breakage. Kussmul Electronics does not warrant the connector.

## II. ABOUT CONNECTORS

The Super 30 Auto Eject -AE is supplied with mating connector p/n 091-169-CON-3P-250. This is a special connector in which 1 pin is an air connection. Do not replace with similar connectors that do not have the air connection. Use only the Kussmul Electronics supplied connector.

## III. ANNUAL MAINTENANCE

1. Lubricate air fitting with Teflon lubricant (non petroleum base)
2. Lubricate electrical fittings with graphite-petroleum lubricant.
3. Check all gaskets and replace if warn.

# INSTALLATION INSTRUCTIONS

## I. FIGURE 1, MOUNTING INSTRUCTIONS

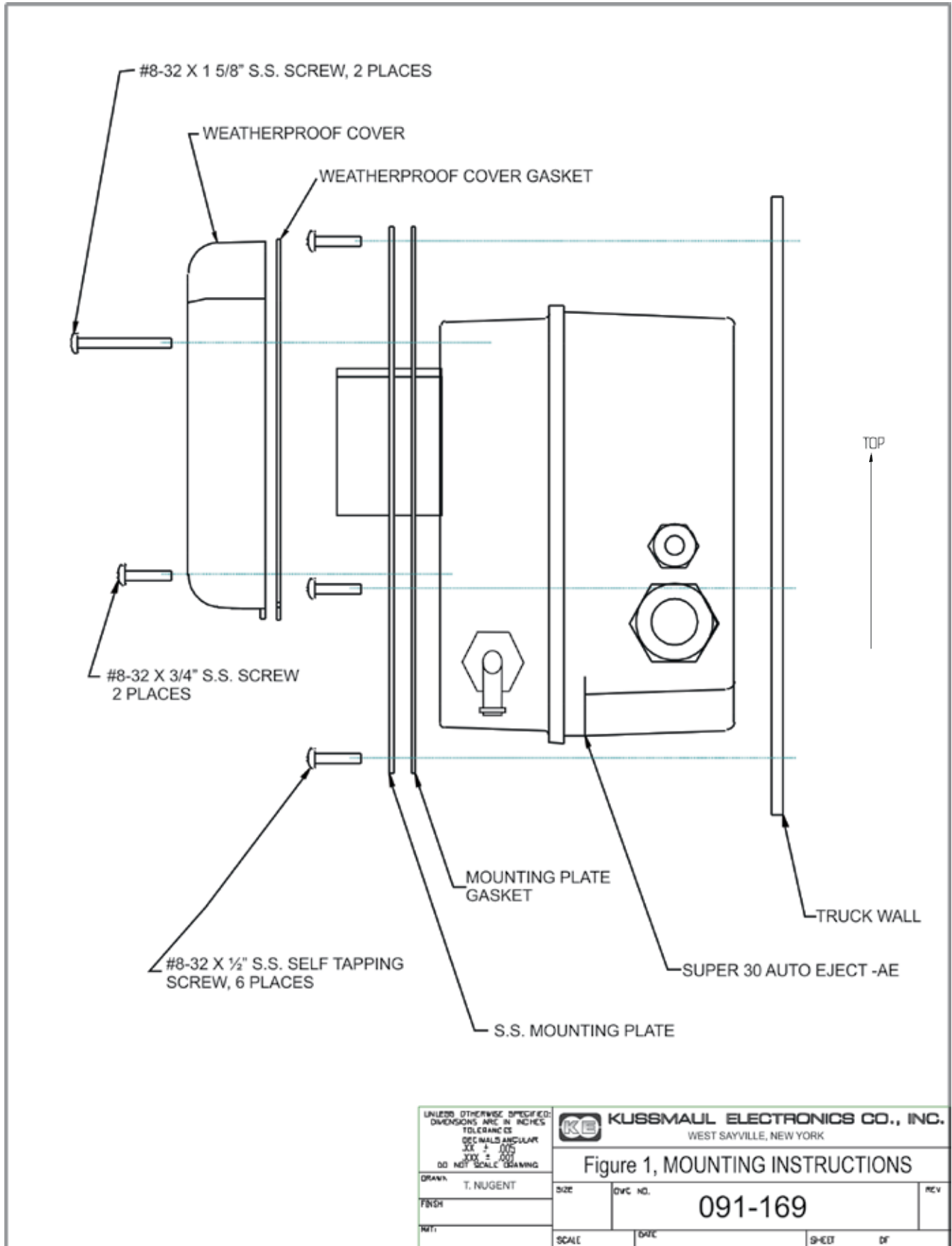

## II. FIGURE 2, AC WIRING

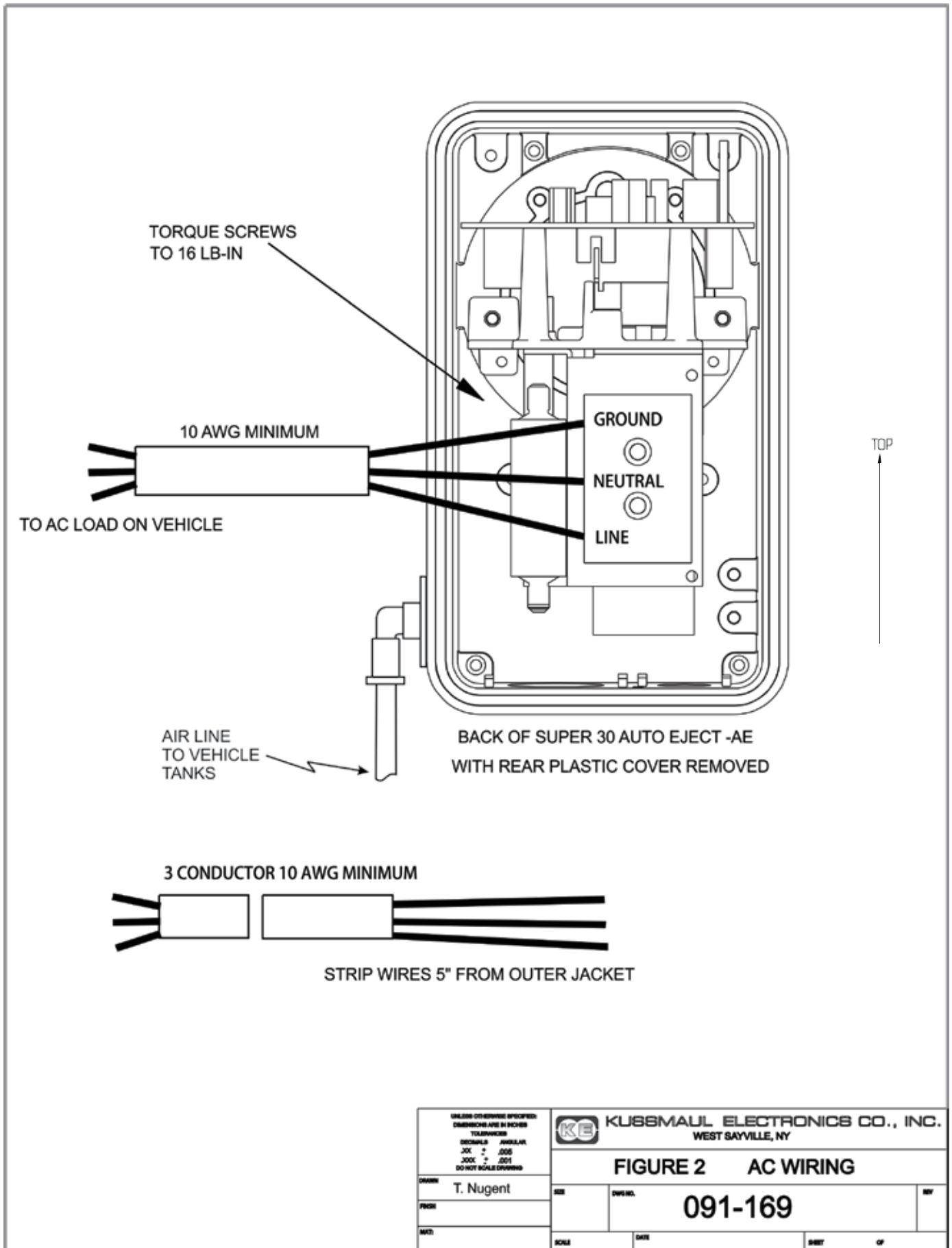

### III. FIGURE 3, DC WIRING

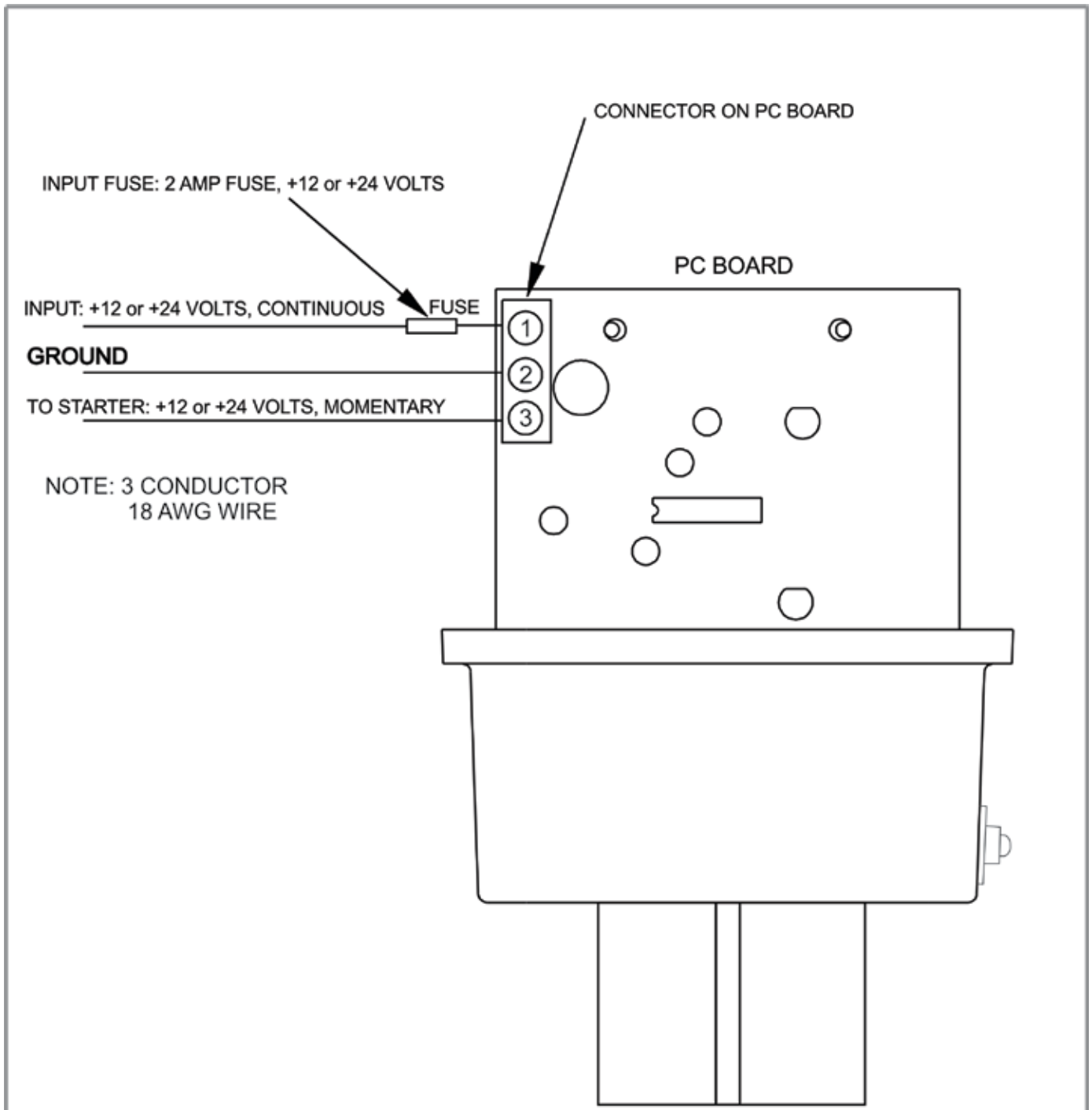

TOP OF SUPER 30 AUTO EJECT -AE  
WITH REAR PLASTIC COVER REMOVED

<small>UNLESS OTHERWISE SPECIFIED: DIMENSIONS ARE IN INCHES TOLERANCES</small>		 <b>KUSSMAUL ELECTRONICS CO., INC.</b> WEST SAYVILLE, NY	
<small>DECIMALS    ANGULAR .XX    ± .005 .XXX   ± .001 DO NOT SCALE DRAWING</small>		<b>FIGURE 3: DC WIRING</b>	
<small>DRAWN</small> T. Nugent	<small>DWG NO.</small> 091-169	<small>REV</small> D	
<small>DATE</small>	<small>SCALE</small>	<small>DATE</small> 12-17-2012	<small>REV</small> OF

#### IV. FIGURE 4, HOLE TEMPLATE

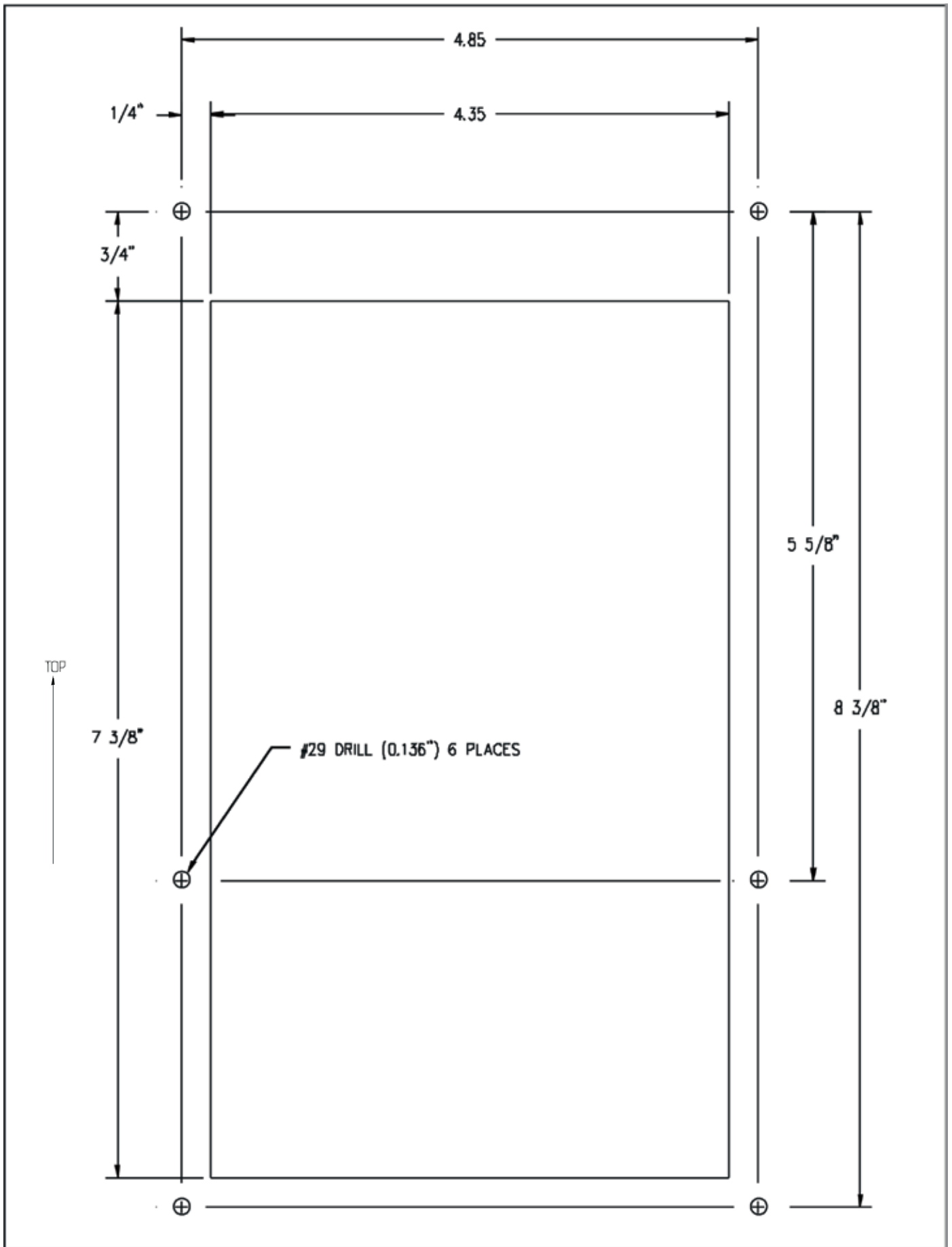



## V. FIGURE 5, CONNECTOR

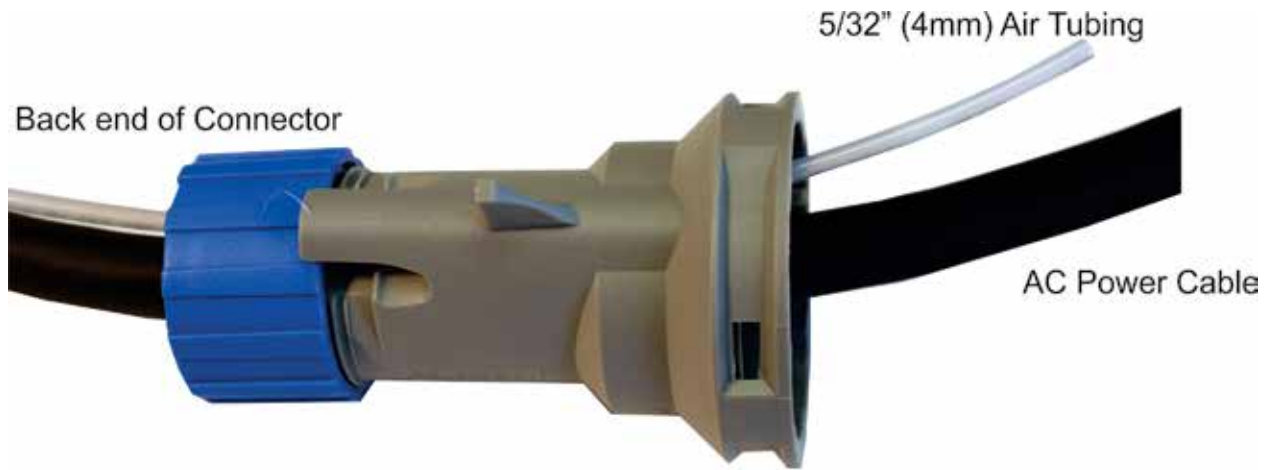

## VI. FIGURE 6, CONNECTOR WIRING

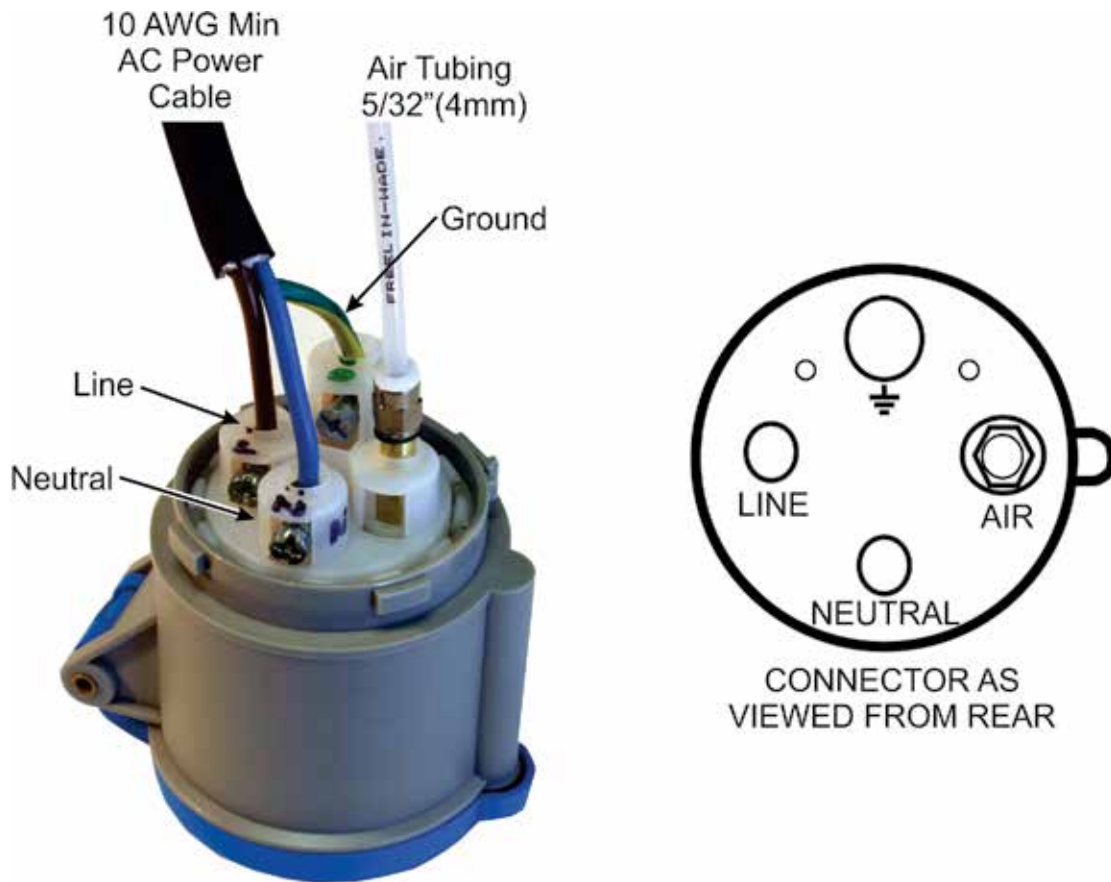

## VII. FIGURE 7, CONNECTOR LOCKING WINGS



## VIII. FIGURE 8, FLEX GUARD

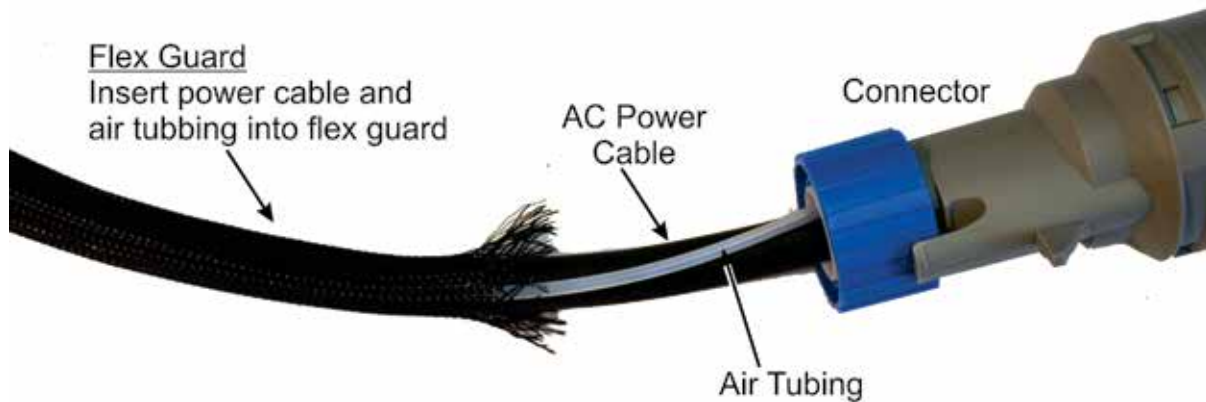

## IX. FIGURE 9, PVC TAPE

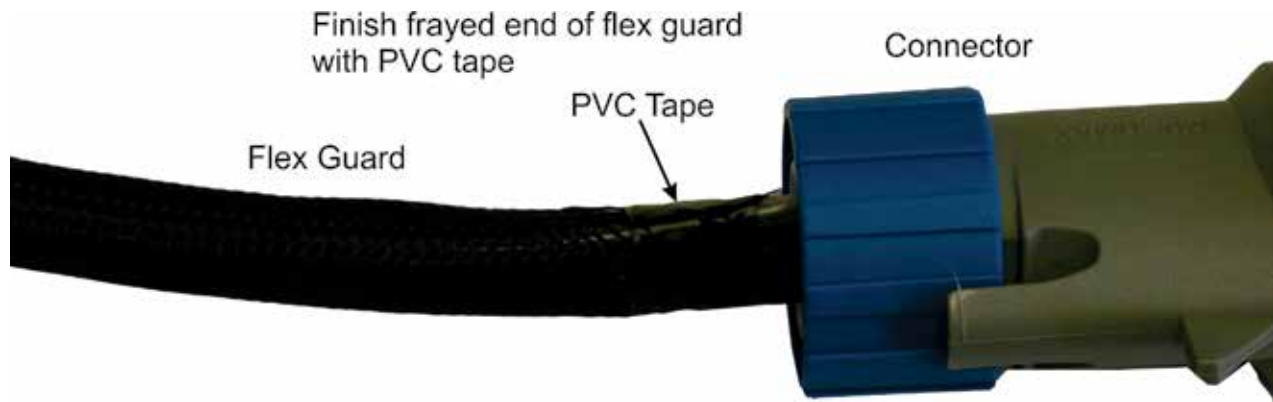

**X. FIGURE 10, SUPER 30 -AE INSTALLATION**

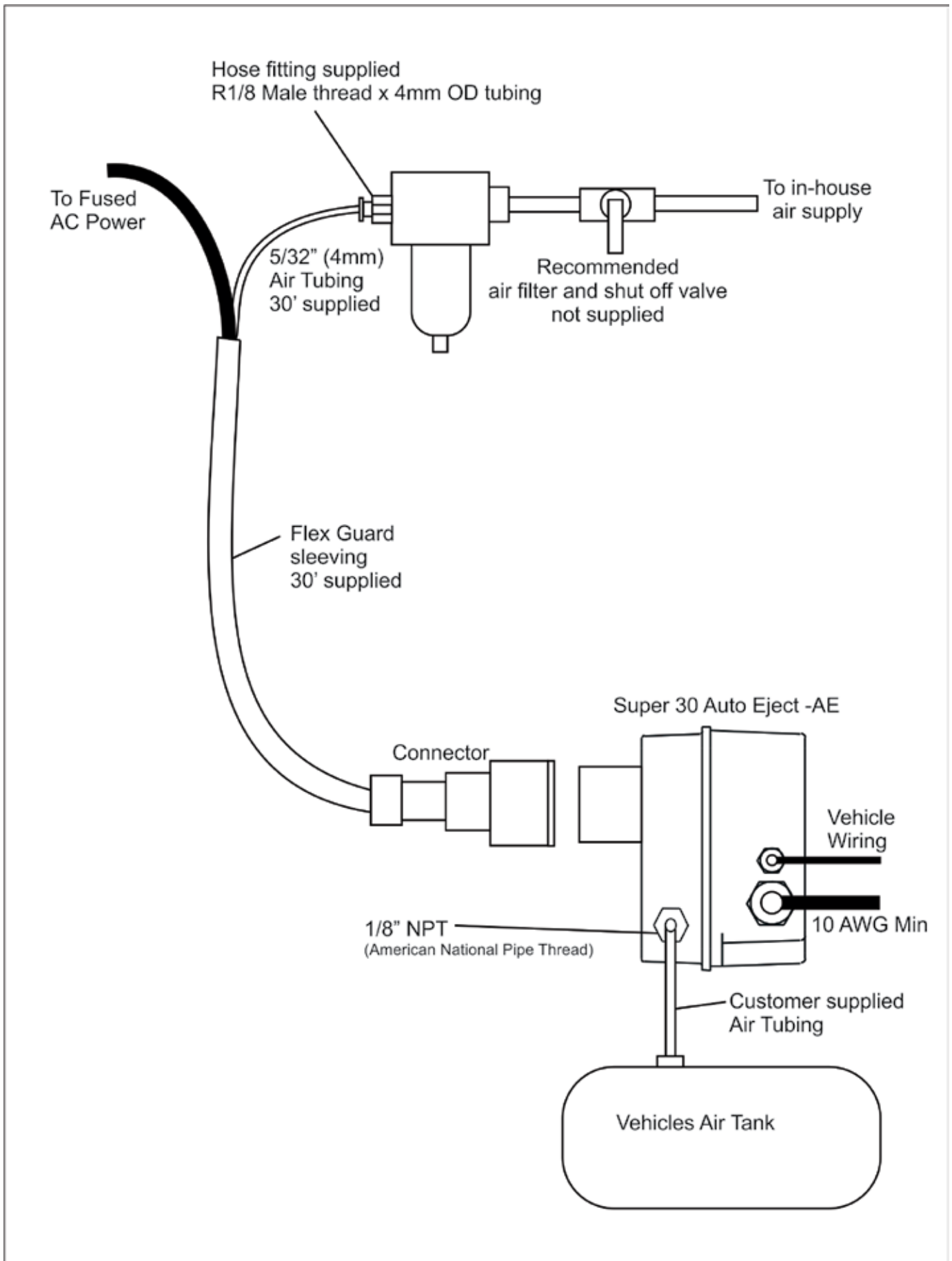

# OUTLINE DRAWING

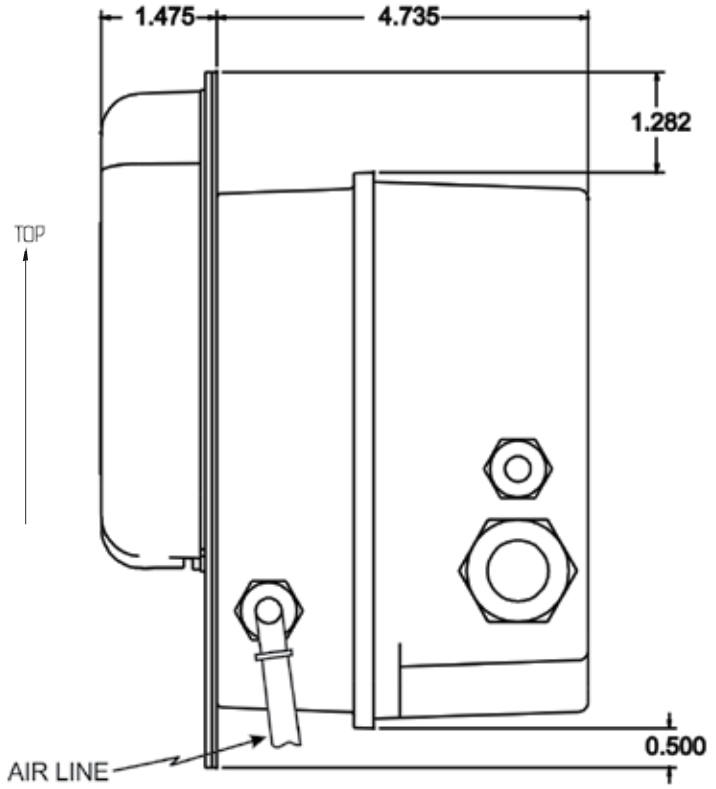
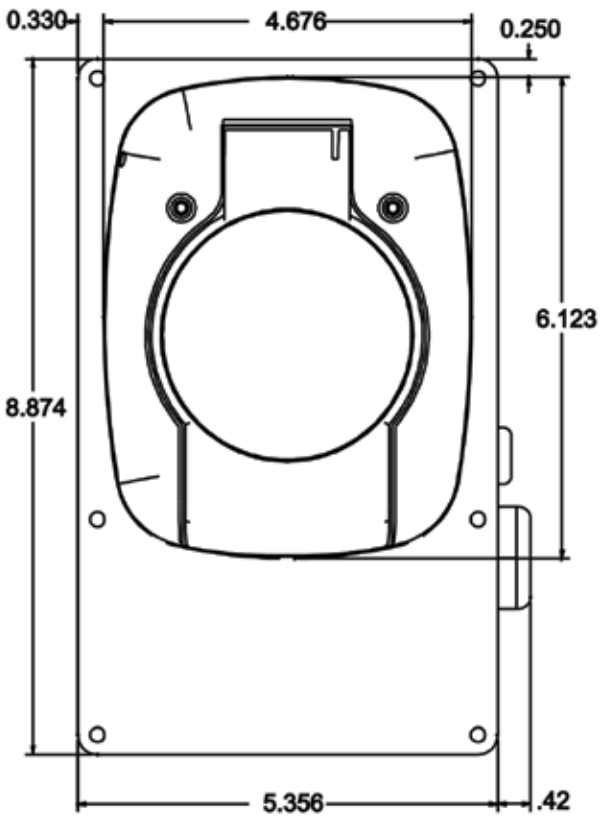
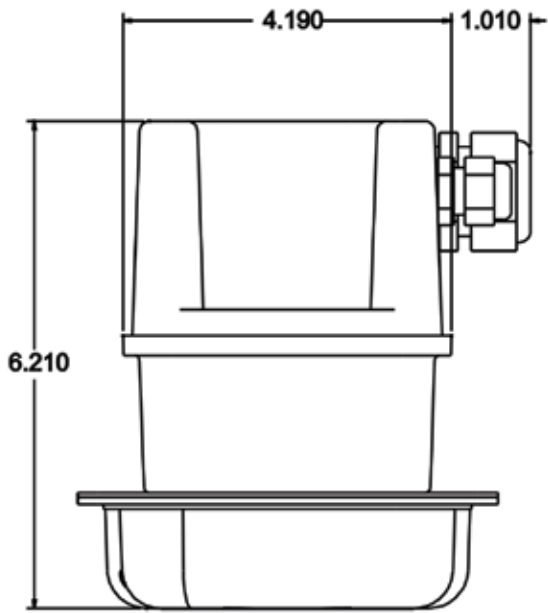

UNLESS OTHERWISE SPECIFIED  
DIMENSIONS ARE IN INCHES  
TOLERANCES  
DECIMALS ANGULAR  
XXX ± .005  
XXX ± .001  
DO NOT SCALE DRAWING



KUSSMAUL ELECTRONICS CO., INC.  
WEST SAYVILLE, NY

## FIGURE 11: OUTLINE DRAWING

DRAWN  
**T. Nugent**  
CHECKED  
DATE

SIZE DWG. NO. **091-169** REV.

SCALE DATE SHEET OF

# SPECIFICATIONS

---

**Input Voltage:** 10 - 28 Volts DC

**Input Current:** 1.6 Amperes Max

**External Fuse:** 2 Ampere

**Electrical Rating:** 250 Volts AC, 30 Amperes Max

**Air Rating:** 175 PSI Max

**Hardware Pack Provided:** Inline fuseholder with fuse, mounting plate with gasket, cover with gasket, blue/gray mating connector, mounting screws, R1/8 x 4mm fitting,

**Air Line Provided:** 5/32" (4mm), 30'

**Flex Guard Provided:** 30' of sleeving

**Weight:** 7 pounds

# INSTALLATION RECORD

---

**DATE INSTALLED** \_\_\_\_\_

**INSTALLED BY** \_\_\_\_\_

**VEHICLE IDENTIFICATION** \_\_\_\_\_

**VEHICLE OWNER** \_\_\_\_\_

# WARRANTY POLICY

---

All Super 30 Auto Ejects manufactured by Kussmaul Electronics are warranted to be free of defects of material or workmanship. Liability is limited to repairing or replacing at our factory, without charge, any material or defects which become apparent in normal use within 2 years from the date the equipment was shipped. Equipment is to be returned, shipping charges prepaid and will be returned, after repair, shipping charges paid.

Kussmaul Electronics shall have no liability for damages of any kind to associated equipment arising from the installation and/or use of the Kussmaul Electronics products. The purchaser, by the acceptance of the equipment, assumes all liability for any damages which may result from its installation, use or misuse, by the purchaser, his or its employees or others.



Members of  
Fire and Emergency  
Manufacturers and  
Service Association



Members of  
National Fire  
Protection  
Association



Members of  
Fire Apparatus  
Manufacturers  
Association



---

170 Cherry Avenue  
West Sayville, NY 11796  
www.kussmaul.com



Ph: 800-346-0857  
Fax: 631-567-5826  
sales@kussmaul.com