

# SAFETY LOCK 4

ANIT-THEFT DEVICE

**A CONTROLLER WHICH PERMITS  
UNATTENDED ENGINE OPERATION  
BUT PREVENTS UNAUTHORIZED  
USE OF THE VEHICLE**

**SIMPLE INSTALLATION**

**PERMITS ENGINE  
TO RUN WITH THE  
IGNITION KEY REMOVED**

**ENGINE STOPS AND CANNOT BE  
RESTARTED IF ATTEMPT IS MADE  
TO DRIVE AWAY**



MODEL #091-160

This simple, low cost controller bypasses the ignition switch when activated by the closure of a momentary switch. The operator may then remove the ignition key without shutting the engine down. Movement of the vehicle is prohibited by interlocking the SAFETY LOCK 4 with the brake light switch, a neutral safety switch on the gearshift or a parking brake operated switch. Operating any one of these will cause the relays in the SAFETY LOCK 4 to drop out and interrupt the ignition circuit to stop the engine. The authorized operator need only insert the key and turn on the ignition to operate the vehicle. With the key in the lock and turned on, the ignition circuit is completed as normal and the opening of the SAFETY LOCK 4 relays has no effect on engine operation.

The SAFETY LOCK 4 contains 4 relays to permit energizing 3 auxiliary circuits in addition to the ignition switch bypass.

## SPECIFICATIONS:

**Volts:** 12 volts, D.C.

**Relay Contacts:** Normally open, 30 Amps.

**Weight:** 4 ounces

**Enclosure:** Unsealed

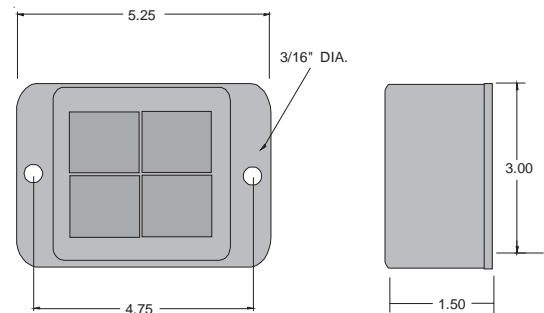

OUTLINE DRAWING

170 Cherry Avenue  
West Sayville, NY 11796  
www.kussmaul.com

**KE** **KUSSMAUL™**  
**ELECTRONICS**  
ENERGIZED AND READY, WHEN SECONDS COUNT

Ph: 800-346-0857  
Fax: 631-567-5826  
sales@kussmaul.com

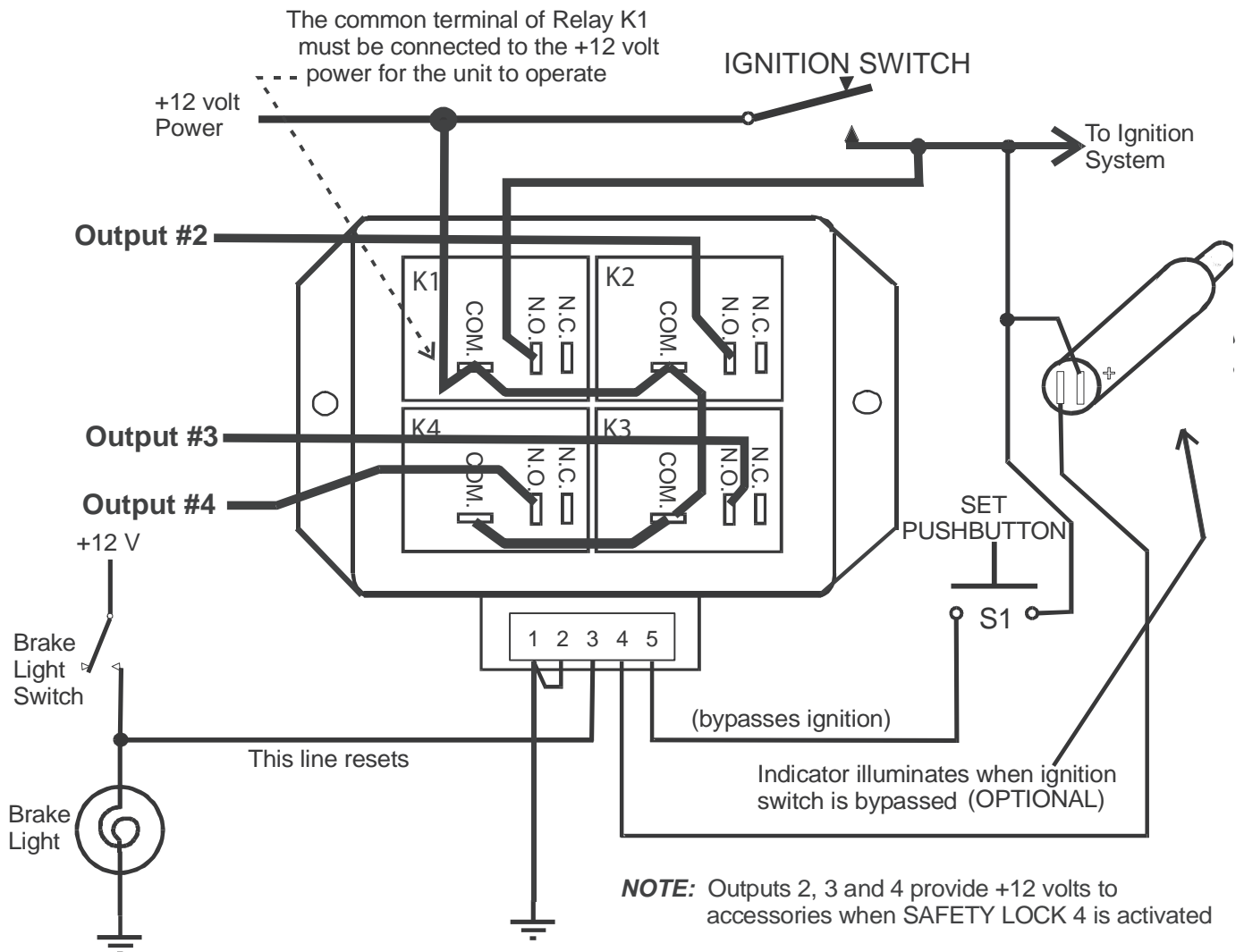

#### INSTALLATION:

1. Mount unit in a suitable location protected from moisture and excessive heat.
2. Wire in accordance with the wiring diagram above

#### OPERATION:

1. With the engine running depress the momentary SET switch S1. The relay will close, the LED will be illuminated and the engine will continue to run when the key is removed.
2. Remove the key from the ignition. The LED will continue to be illuminated and the engine will continue to run.
3. Step on the foot brake. The LED will go out and the engine will stop.
4. Start the engine and repeat step 1.
5. Insert the key, turn ignition switch to ON and verify that the engine continues to run when the brake pedal is depressed.

### MODEL 091-160 SAFETY LOCK 4

A Controller To Permit Engine Operation With The Ignition Switch Removed

## INSTALLATION AND WIRING INSTRUCTIONS