

## INSTRUCTION MANUAL

---

# AUTO PUMP TIMER

A TIMER TO LIMIT THE RUNNING TIME OF THE  
AUTO PUMP



**MODEL # 091-150**

INPUT: 12VOLTS, D.C.  
OUTPUT RELAY: 30 AMPS

3 YEAR WARRANTY

## **INTRODUCTION**

---

The Model 091-150 Auto Pump Timer limits the duty cycle of the Auto Pump to 1 hour on and 1 hour off. This is important to the life of the pump when it is operating on a vehicle with an abnormally high leak. The unit prevents the pump from operating at higher temperatures, and thus preserves the long life characteristics of the pump.

## **INSTALLATION**

---

1. Mount the unit using the two holes provided for this (see Figure 2)...
2. Open the Pressure Switch assembly (mounted on the Auto Pump), and move the red wire running to the motor from the pressure switch to the N.O. terminal on the timer as shown in Figure 1.
3. Connect a 14AWG wire to the “Com” terminal of the relay on the timer. Use an un-insulated ¼” female quick disconnect.
4. Connect the other end of this wire to the open terminal on the pressure switch – see Figure 1.
5. Check all wiring before proceeding
6. Close the Pressure Switch assembly.
7. The yellow LED on the Model 091-150 Auto Pump Timer, when lit, indicates that the pump is in the “rest” portion of its cycle and the motor is not running.

## **SPECIFICATION AND OUTLINE**

---

Input Power: 12VDC (from Pressure switch input to relay COM).

Input Current Draw: 80 ma. with pump running, 10 ma. with pump resting.

Relay Contact Rating: 30 amps @ 14 VDC

Weight: 4 ounces

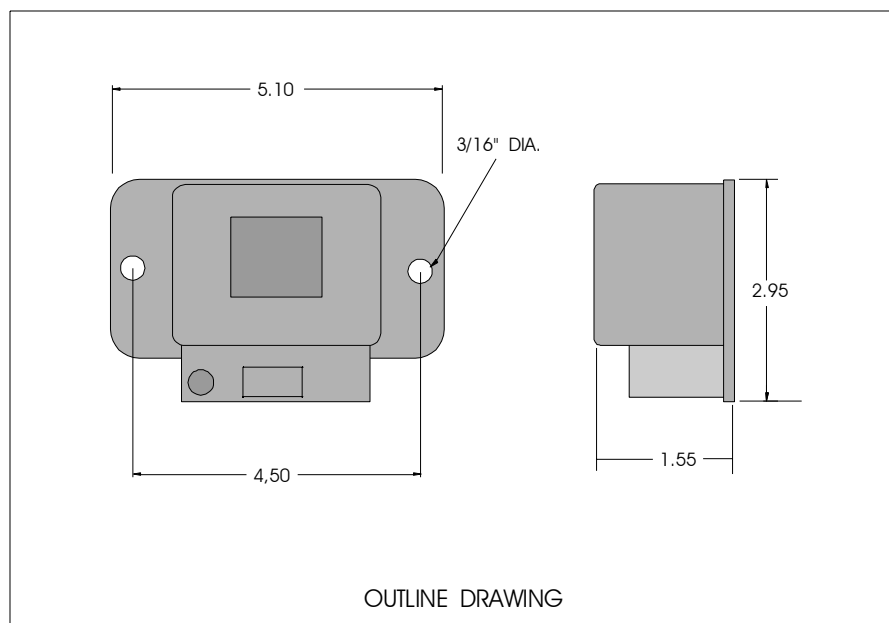
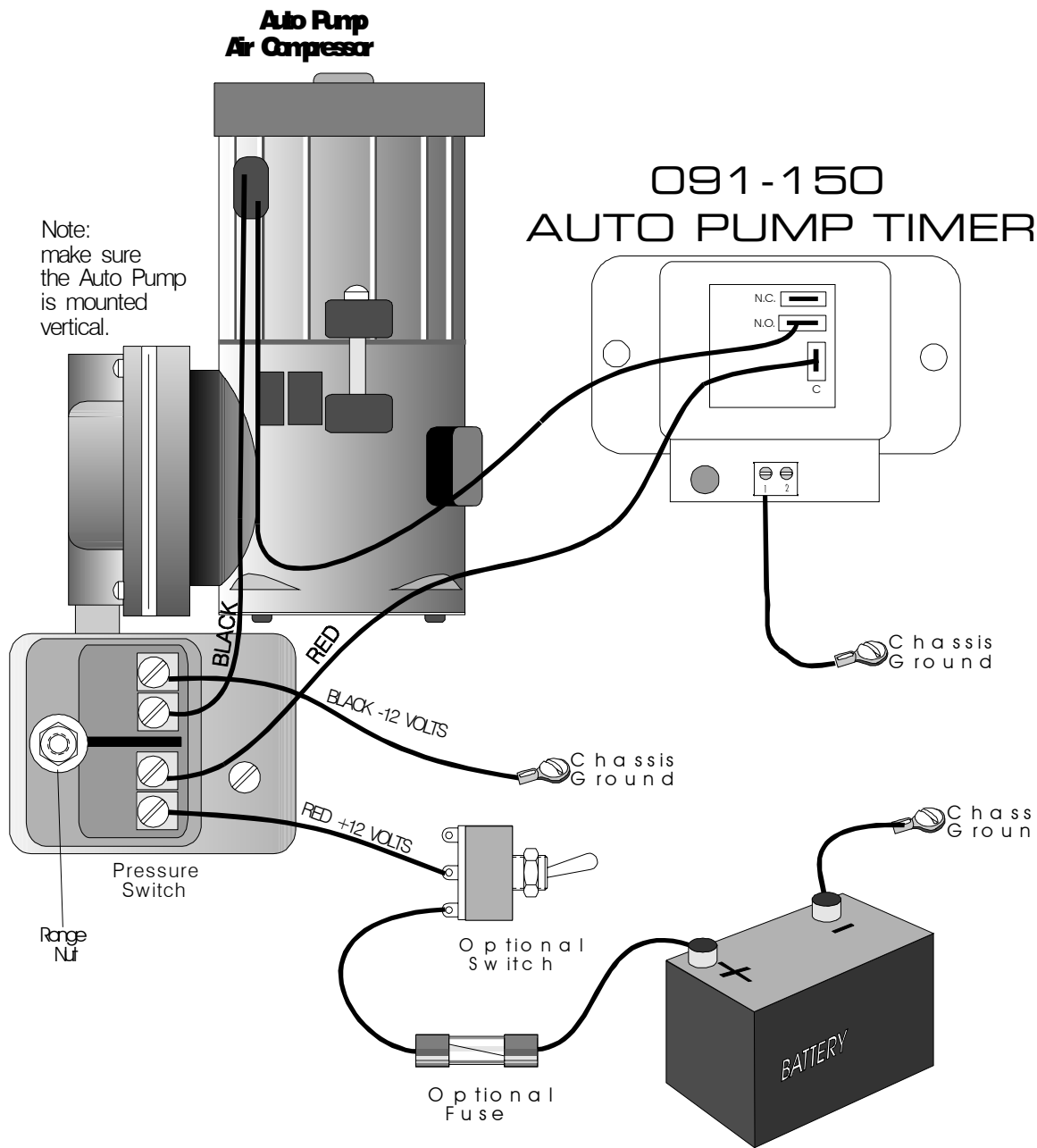

Figure 2



**CAUTION:** Observe correct polarity connections  
Red lead to motor and timer **MUST** be positive

Figure 1  
Installation Wiring

# **INSTALLATION RECORD & WARRANTY**

---

**Date Installed**\_\_\_\_\_

**Installed By**\_\_\_\_\_

**Vehicle Identification**\_\_\_\_\_

**Vehicle Owner**\_\_\_\_\_

## ***WARRANTY***

All products of Kussmaul Electronics Company Inc. are warranted to be free of defects of material or workmanship. Liability is limited to repairing or replacing at our factory, without charge, any material or defects which become apparent in normal use within 3 years from the date the equipment was shipped. Equipment is to be returned, shipping charges prepaid and will be returned, after repair, shipping charges paid.

Kussmaul Electronics Company, Inc. shall have no liability for damages of any kind to associated equipment arising from the installation and /or use of the Kussmaul Electronics Company, Inc. products. The purchaser, by the acceptance of the equipment, assumes all liability for any damages which may result from its installation, use or misuse, by the purchaser, his or its employees or others.