

AUTO CHARGE DUAL

AUTOMATIC DUAL OUTPUT BATTERY CHARGER



MODEL # : 091-145-12

INPUT: 120 Volt, 50/60 Hz, 3.5 Amps

OUTPUT BAT 1: 10 Amps
OUTPUT BAT 2: 10 Amps

File: IM_091-145-12_revb.indd
Rev: B
Revised By: MFG
Date: 3-25-2014

3 YEAR WARRANTY



scan using your mobile
device for more information

170 Cherry Avenue
West Sayville, NY 11796
www.kussmaul.com

KE KUSSMAUL™
ELECTRONICS
ENERGIZED AND READY, WHEN SECONDS COUNT

Ph: 800-346-0857
Fax: 631-567-5826
sales@kussmaul.com

IMPORTANT SAFETY INSTRUCTIONS

I. PERSONAL PRECAUTIONS:

1. Someone should be within range of your voice or close enough to come to your aid when you work near a lead-acid battery.
2. Have plenty of fresh water and soap nearby in case battery acid contacts skin, clothing, or eyes.
3. Wear complete eye and clothing protection. Avoid touching your eyes while working near a battery.
4. If battery acid contacts skin or clothing, wash immediately with soap and water. If battery acid enters the eye, immediately flood eye with cold running water for at least 10 minutes and get medical attention immediately.
5. **NEVER** smoke or allow a spark or flame in the vicinity of the battery or engine.
6. Be extra cautious to reduce the risk of dropping a metal tool onto the battery. It might spark or short-circuit the battery or other electrical part and cause a fire or an explosion.
7. Remove personal metal items such as rings, bracelets, necklaces, and watches when working with a lead-acid battery. A lead-acid battery, when shorted, can produce a current sufficient to weld a ring or the like metal causing a severe burn.
8. Use the battery charger for charging gel-cell, AGM and flooded lead-acid batteries only. Do not use the charger for charging dry-cell batteries that are commonly used with home applications. These batteries may burst and cause injury to persons and damage to property.
9. **WARNING – RISK OF EXPLOSIVE GASES:** Working in the vicinity of a lead-acid battery is dangerous. Batteries generate explosive gases during normal battery operation.

II. CHARGER PRECAUTIONS:

1. **NEVER** charge a frozen battery.
2. Make sure the cord is located so that it will not be stepped on, tripped over, or otherwise subjected to damage or stress.
3. Do not operate the charger with a damaged cord or plug; replace them immediately.
4. Do not operate the charger if it has received a sharp blow, been dropped, or otherwise damaged.
5. Do not disassemble the charger. Incorrect reassembly may result in a risk of electric shock and fire.
6. To reduce the risk of electric shock, disconnect the charger from the AC source before attempting any maintenance or cleaning.
7. **LOCATION OF CHARGER:** The charger should be mounted on a wall, vehicle floor, ventilated compartment or other suitable surface as close to the batteries to be charged as possible. Do not block the charger's fan or air intakes. Do not mount the charger directly over the batteries as fumes may cause excessive corrosion. The area should be well ventilated and free from excessive moisture, exhaust manifolds, and battery fumes. For maximum performance, the charger should not be located in an area of extreme high temperature. The charger is not waterproof. Do not mount the charger where there is a possibility of water entering the unit. Evidence of water entry into the charger will void the warranty.
8. **CAUTION:** Do not attempt to increase battery bank capacity by splitting the output of one of the banks with a diode-type battery isolator. The diode isolator lowers the charger voltage and results in under-charging the batteries connected to it. If additional capacity is required it is preferable to add another isolated or parallel battery.

III. GROUND AND AC POWER CORD CONNECTION:

1. The charger should be grounded via the AC power connection to reduce the risk of electrical shock.
2. The charger must be plugged into or wired to an outlet that is an over-current protected 3 prong outlet. Alternatively, it may be routed through a separate dedicated fuse or circuit breaker on an AC distribution panel with proper earth/safety ground. All wiring shall comply with UL recommendations, NEC or NFPA standards and local ordinances. Never alter the AC cord or plug if provided. Any modification of the cord must only be done by a qualified electrician. Improper cord/outlet connection may result in a risk of electrical shock.
3. Observe color coding of the AC wiring as follows:

Black.....	AC Hot or LINE (fused)
White.....	AC Neutral
Green.....	AC Ground (safety/earth)
4. **CAUTION:** (230 VAC applications only): If AC input is provide from a source consisting of two HOT or LINE leads (phase-to-phase 230 VAC input voltage); an external fuse or circuit breaker must be used to protect both hot leads.

INTRODUCTION

The Auto Charge Dual is a compact, completely automatic dual output battery charger designed specifically for installations that require 24 volts for starting and 12 volts for accessories. The two batteries are connected in series to obtain 24 volts and the output of each charger is connected to each battery. Each output of the charger is individually controlled to charge its particular battery and is electrically isolated from the other. Two separate ammeters indicate the output current to each battery.

FEATURES

I. AUTO CHARGE DUAL BATTERY CHARGER

- Electronic remote sensing of true battery voltage, eliminates the need for sensing wires
- Automatic current limiting
- Automatically Charges Dual Banks of Batteries
- Charges Both the 24 Volt & the 12 Volt Batteries Independently
- Designed Specifically for Vehicles with Dual Battery Systems
- Charging the 12 Volt Battery Does Not Effect the 24 Volt Battery
- Front ammeter indicators

II. CHARGE CONTROLS & ELECTRONIC REMOTE SENSING

The Auto Charge Dual contains a precision voltage controller to maintain the battery's charge. Automatic electronic remote sensing measures the true battery voltage, eliminating the need for the additional sense wires. The output current of any charger is inherently a series of pulses whose frequency is determined by the power line frequency. Therefore, there are brief intervals during which no charging current flows. Since there is no charging current there is also no voltage drop between the charger and the battery. The Auto Charge Dual measures and stores the true battery voltage. This battery voltage is compared to a reference voltage, any error detected is then used to control the charger output at the desired level. There is no "trickle charge" and therefore no danger of overcharging and water boil-off.

III. AUTOMATIC CURRENT LIMITING

When batteries are severely discharged, some battery chargers can be overloaded due to the high charging current required. The Auto Charge Dual contains an automatic current limit. The current limit feature limits the output current to 20 amperes when charging a deeply discharged battery or if the starter cranks the engine while charging. The current limiter thus eliminates the need for an ignition interlock circuit.

WIRING

I. BATTERY CHARGER WIRING INSTRUCTIONS

1. Refer to Installation Wiring Diagrams I and II.
2. Refer to Wiring Specifications to determine the recommended wire size and maximum lengths. Using a smaller gauge may cause overheating of the terminal. Additional information is available upon request if longer, larger wiring is required.
3. Double check all wiring before applying AC power to input terminal.
4. Apply AC power (shoreline power) to input terminal and observe that the charger is operating.
5. Verify that the battery voltage appears at the charger output terminals. A minimum of 9 volts is required to start the charger

II. WIRING SPECIFICATIONS

Length of Wire to Battery (feet)	0-5			5 - 10			10 - 20*		
Battery Charger Connections	COM -	V. BAT1 +	V. BAT2 +	COM -	V. BAT1 +	V. BAT2 +	COM -	V. BAT1 +	V. BAT2 +
Wire # Gauge (awg)	12	12	12	10	10	10	8	8	8
* Consult factory if length of wire to battery is longer than 20 feet									

INSTALLATION WIRING DIAGRAM

I. FOR 2 INDIVIDUAL BATTERIES

Wiring Diagram shown is for a 10 foot installation

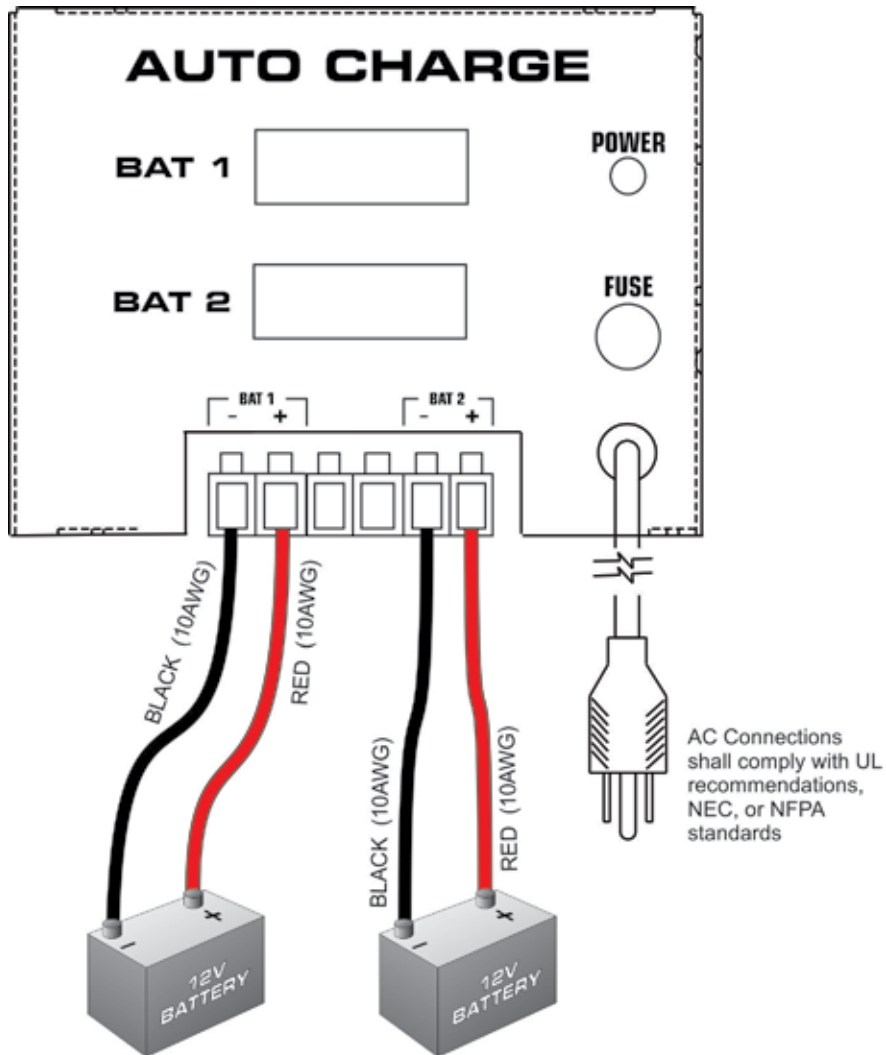

II. FOR 24 VOLT STARTER AND 12 VOLT ACCESSRIES

Wiring Diagram shown is for a 10 foot installation

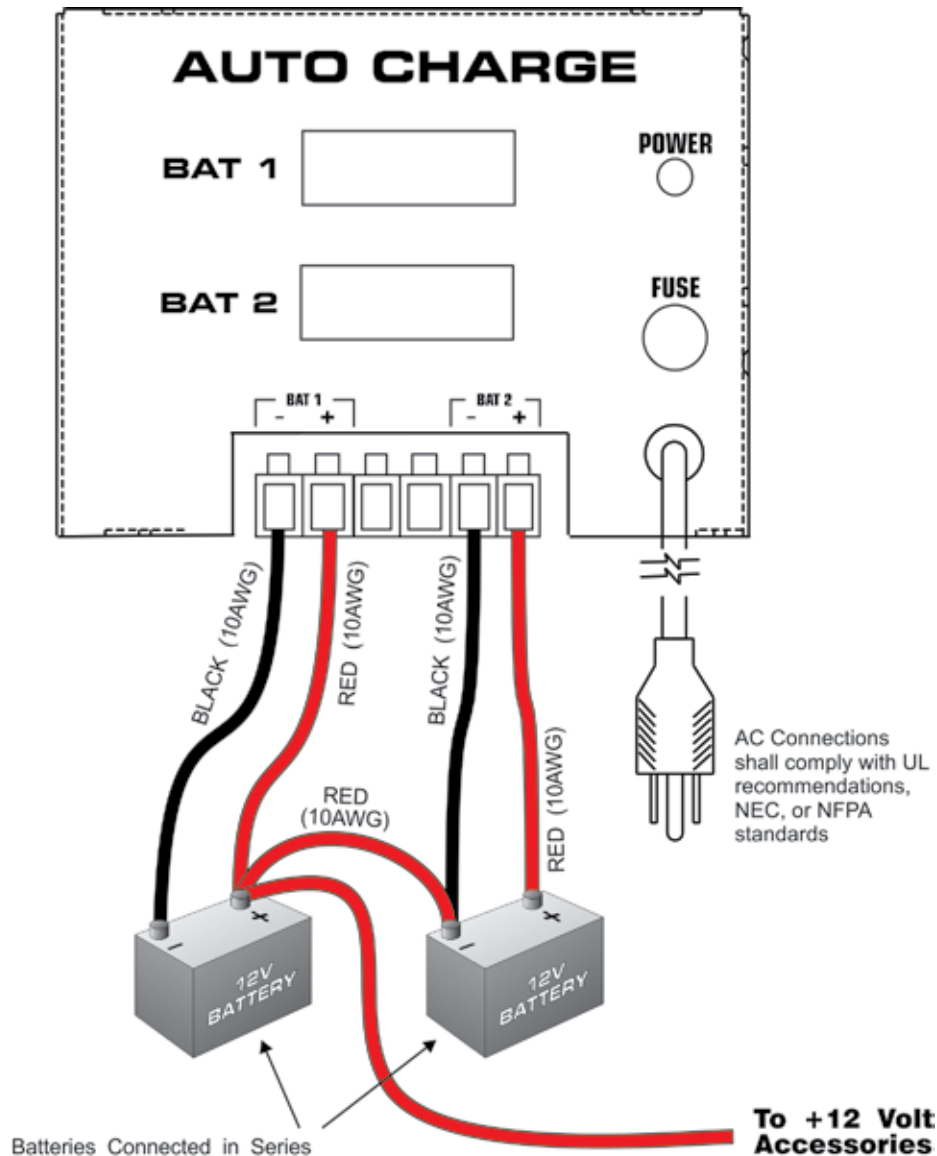

The Series connection of the two 12 volt batteries produces 24 volts. Each battery is individually charged at 12volts. Even though the batteries may supply different loads, each battery is automatically supplied with the correct charging current. When each of the batteries is fully charged, the charger stops charging.

SPECIFICATIONS

Input Power: 120 Volt, 50/60 Hz, 3.5 Amperes

Input Voltage Range: 105-132 VAC

Input Current Max (@132 VAC): 5 Amps

Inrush Current: 7 Amps

Input Fuse: 8 Ampere, fast acting

Output Power - Bat 1 & Bat 2: 12 Volts DC, 20 Amperes Max, Total Output

Output Voltage (No Load): 13.25 VDC (per output)

Output Voltage Tolerance (No Load): +/- 0.4%

Output Voltage (Full Load): 13.12 VDC

Output Power: 131 Watts per output (262 Total)

Output Ripple: 0.5 Vrms @ Charger, 0.1 Vrms @ Battery

Efficiency: >62%

Line Regulation: <0.4%

Load Regulation: <1%

Storage Temp: -20 to 80 C

Operating Temp: 0 to 40 C

Isolation (Hi-pot): 1200 VDC

Weight: 22 pounds

Short Circuit Protected: Yes

Battery Required To Operate: Yes

Charger Technology: SCR

Output Current Limited: Yes (automatic)

Input Current Limited: Yes (fuse)

Fan: Yes (thermal switch)

OUTLINE DRAWING

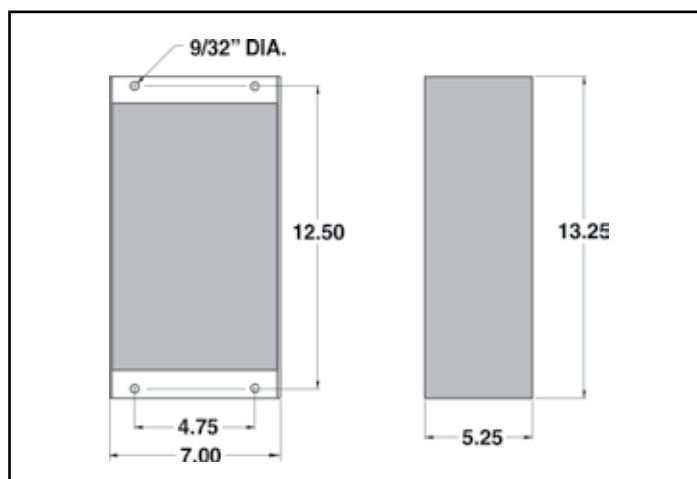

170 Cherry Avenue
West Sayville, NY 11796
www.kussmaul.com



Ph: 800-346-0857
Fax: 631-567-5826
sales@kussmaul.com

INSTALLATION RECORD

DATE INSTALLED _____

INSTALLED BY _____

VEHICLE IDENTIFICATION _____

VEHICLE OWNER _____

WARRANTY POLICY

All products of Kussmaul Electronics Company Inc. are warranted to be free of defects of material or workmanship. Liability is limited to repairing or replacing at our factory, without charge, any material or defects which become apparent in normal use within 3 years from the date the equipment was shipped. Equipment is to be returned, shipping charges prepaid and will be returned, after repair, shipping charges paid.

Kussmaul Electronics Company, Inc. shall have no liability for damages of any kind to associated equipment arising from the installation and/or use of the Kussmaul Electronics Company, Inc. products. The purchaser, by the acceptance of the equipment, assumes all liability for any damages which may result from its installation, use or misuse, by the purchaser, his or its employees or others.



Members of
Fire and Emergency
Manufacturers and
Service Association



Members of
National Fire
Protection
Association



Members of
Fire Apparatus
Manufacturers
Association



170 Cherry Avenue
West Sayville, NY 11796
www.kussmaul.com



Ph: 800-346-0857
Fax: 631-567-5826
sales@kussmaul.com