

INSTALLATION INSTRUCTIONS

Model IN-4 Indicator Panel

The Model IN-4 Indicator Panel is to be used with the Pump Plus HO Battery Charger. This indicator has a Green Led to show the batteries are fully charged and the charger is not charging and Red Led to show the charger is charging.

To Mount the IN-4:

1. Remove the two screws installed on the indicator. These are for factory assembly purposes only.
2. Locate a suitable spot on the vehicle and mark the desired location.
3. Drill out the three holes. Use a 1" hole saw for the wires and a 5/32" diameter drill for the two screw holes. See diagram below for hole dimensions.
4. Mount indicator to the vehicle with the two # 6-32 screws provided.
5. Connect the wiring as shown in wiring diagram for the Pump Plus HO charger.

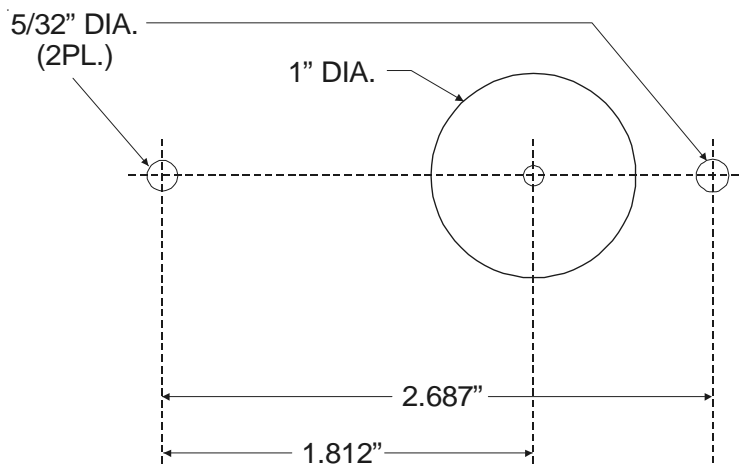

SINCE 1967, DESIGNERS OF INNOVATIVE PRODUCTS

KUSSMAUL ELECTRONICS COMPANY, INC.

170 CHERRY AVENUE, WEST SAYVILLE, NEW YORK, 11796-1221 USA

TEL. In NY: 631 567-0314

TOLL FREE: 800 346-0857

FAX: 631 567-5826

Auto Pump
Air Compressor

Note:
make sure
the Auto Pump
is mounted
vertical.

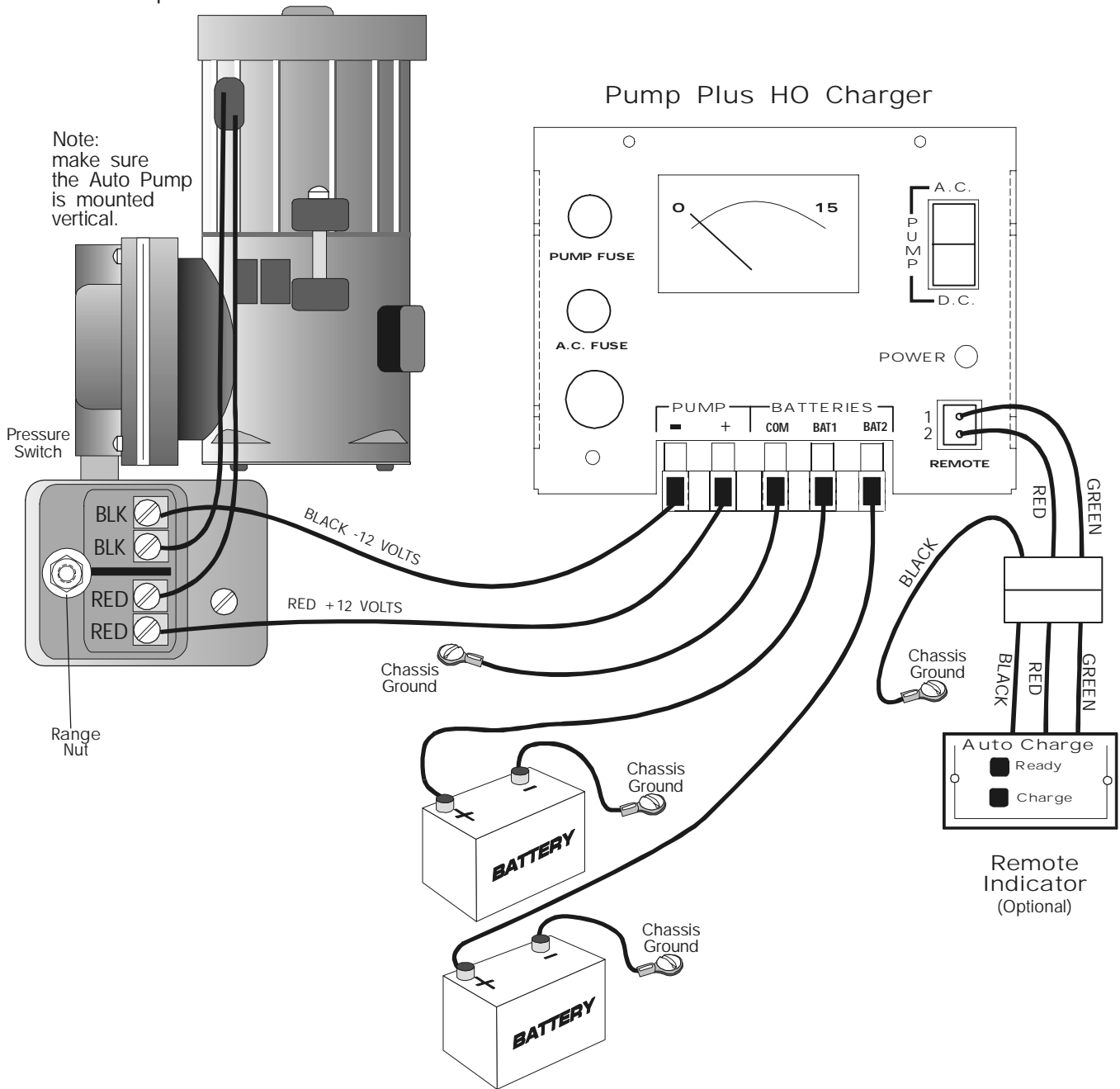

Note: All wire is 14 gauge, larger wire is required if length exceeds 10 feet.

Wiring Diagram Pump Plus HO