

INDICATOR INSTALLATION

1. Locate Indicator in a convenient place on the vehicle.
2. Place the template in position and center punch in 4 places.
3. Drill holes as shown.
4. Cut out square hole.
5. Connect wiring to charger in accordance with the instructions in the charger installation instructions.
6. Install as shown.
7. Insert (4) #8-32 screws supplied and tighten. **(CAUTION: Do not over tighten because you will bend the plastic bezel and break the watertight seal).**

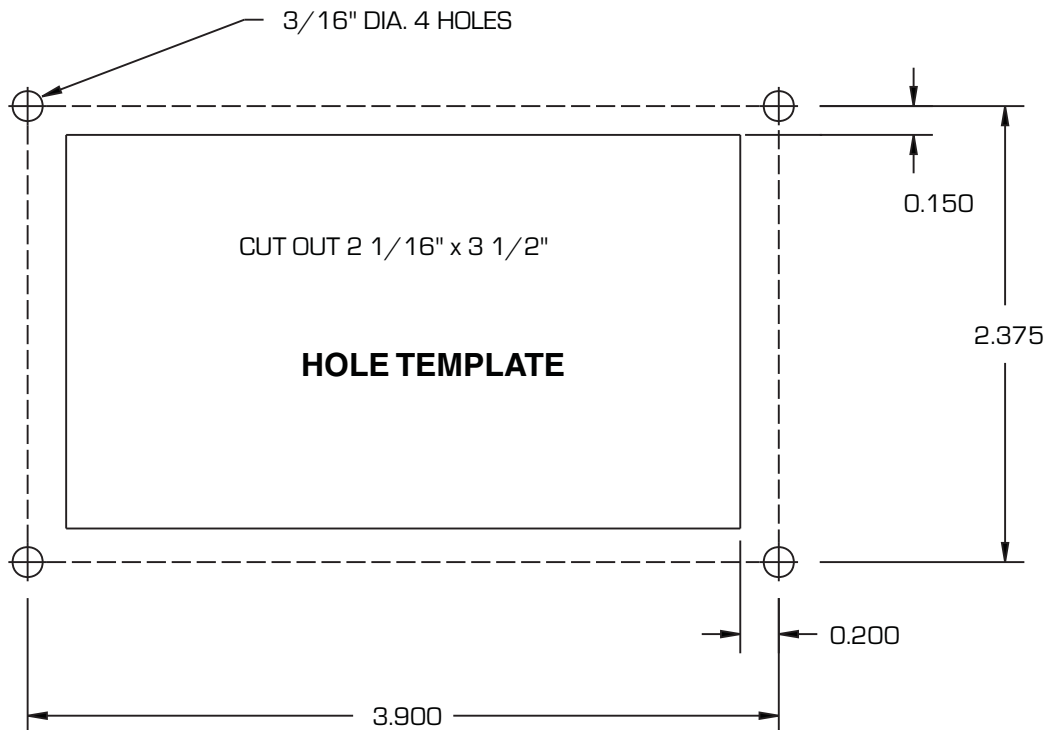
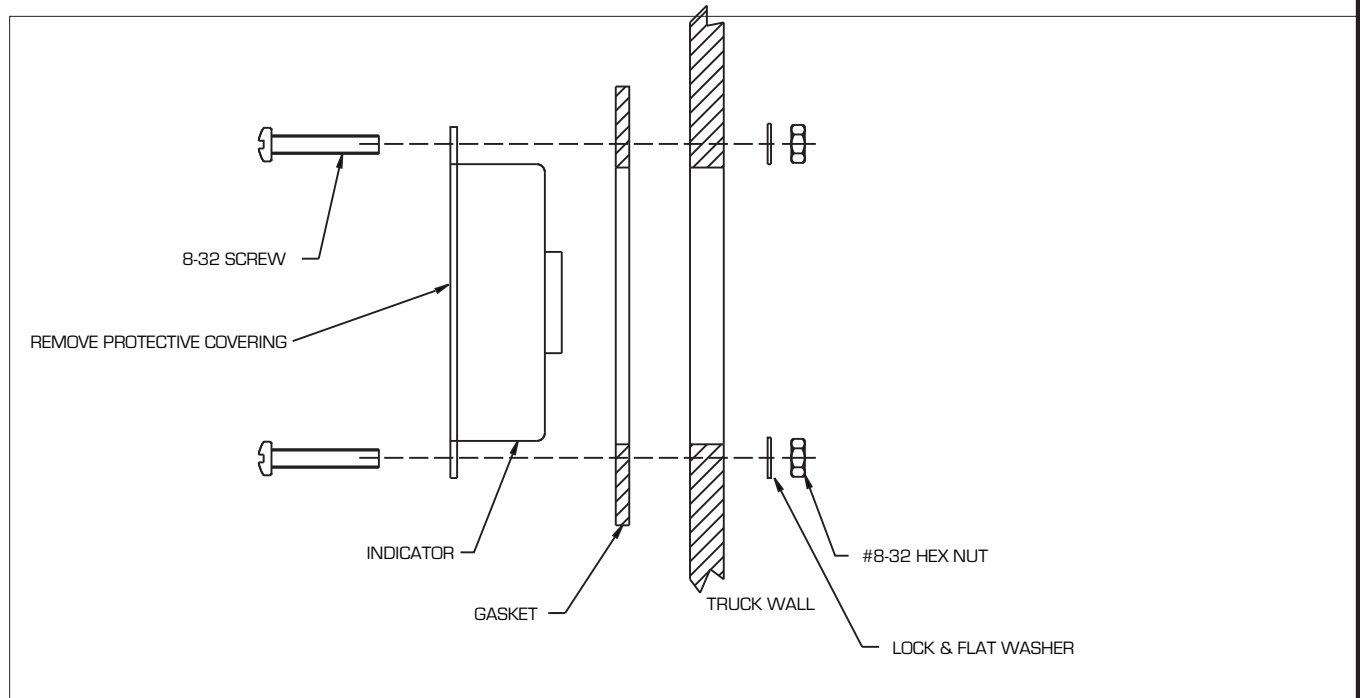

Hole Template may not be to Scale, please check dimensions before using.