

## INSTRUCTION MANUAL

---

# AUTO CHARGE 3

## AUTOMATIC BATTERY CONDITIONER



MODEL #091-26-12

**NOTE:**

**THIS IS A CONDITIONER FOR MAINTAINING THE CHARGE IN A VEHICLE'S BATTERY. IT WILL RECHARGE THE BATTERY SLOWLY BUT IS NOT RECOMMENDED FOR APPLICATIONS WITH AUXILIARY LOADS.**

**INPUT:** 120 VOLT, 50/60 Hz, 1 AMP MAX

**MAX. OUTPUT:** 12 VOLTS, 3 AMPS

**3 YEAR WARRANTY**



**KUSSMAUL ELECTRONICS CO., INC.**

170 CHERRY AVE., WEST SAYVILLE, N.Y. 11796

TEL: in NY 631-567-0314

TOLL FREE: 800-346-0857

FAX: 631-567-5826

# INTRODUCTION

---

The Auto Charge 3 Automatic Battery Charger is a compact, completely automatic charger designed for installation on vehicles with two batteries. An internal charge divider charges both batteries simultaneously while maintaining complete battery isolation. A maximum output of 3 amperes provides sufficient current for vehicles which do not have large constant accessory loads. Indicator lights are provided to signal when the charger is charging and when the charging is complete.

Construction of the Auto Charge 3 is extremely rugged to withstand the shock and vibration normally encountered by vehicle mounted equipment. The unit operates completely automatically and stops charging the batteries when they are fully charged. There is no trickle charge and therefore no danger of overcharging and water boiloff. Parasitic loads on the battery such as a radio, lights, etc., up to a maximum of 2 amps are automatically supplied with current from the charger.

# INSTALLATION WIRING DIAGRAM

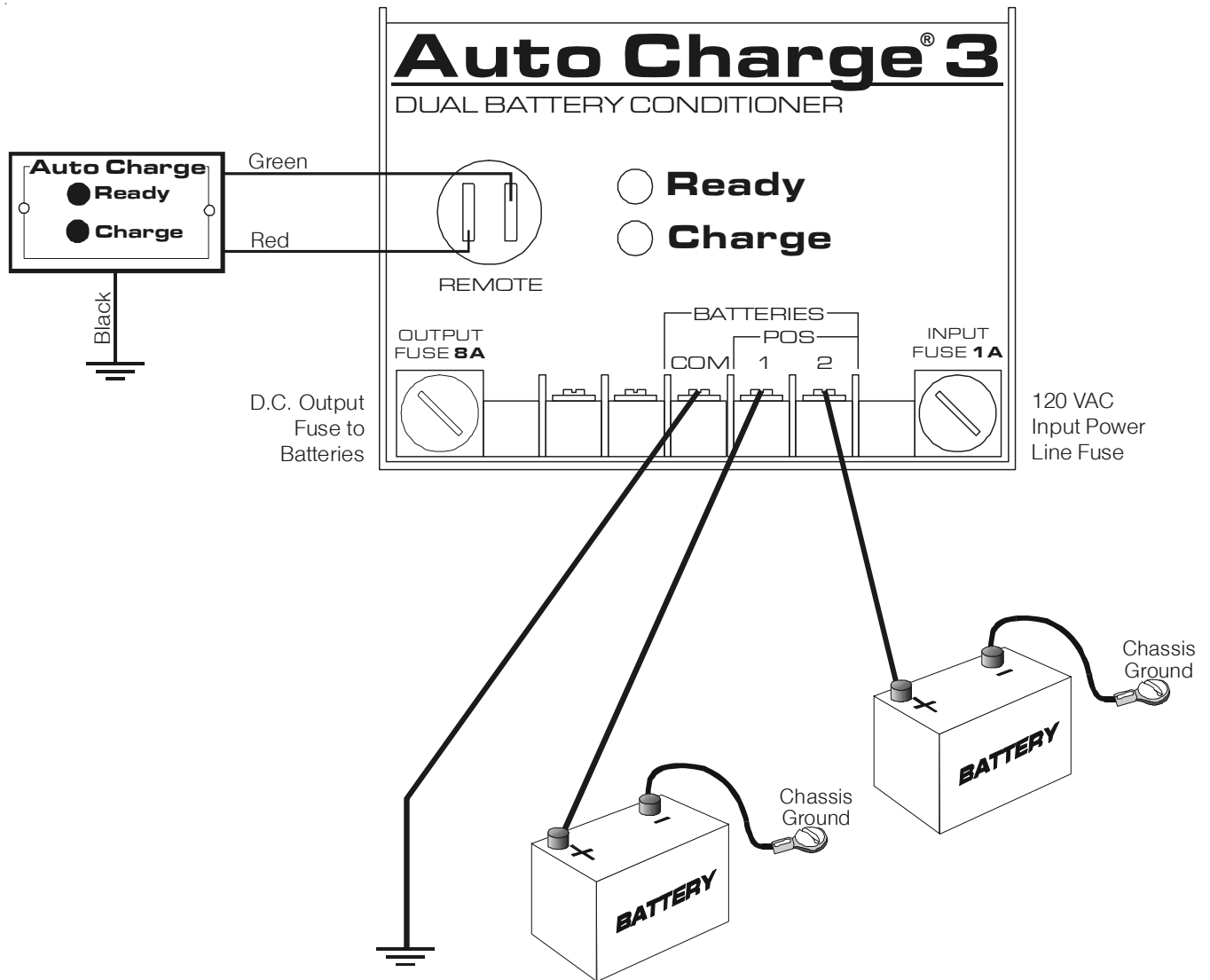

| WIRE SIZE CHART |                |  |           |
|-----------------|----------------|--|-----------|
| CONNECTION      | ITEM           | DEFINITION                             | WIRE SIZE |
| <b>COM</b>      | BATTERY COMMON | NEGATIVE CHARGING LEAD FOR BATTERIES   | 14 AWG    |
| <b>1</b>        | BATTERY NO.1   | POSITIVE CHARGING LEAD FOR BATTERY # 1 | 14 AWG    |
| <b>2</b>        | BATTERY NO.2   | POSITIVE CHARGING LEAD FOR BATTERY # 2 | 14 AWG    |

**IMPORTANT:** Wire size is for a maximum length of 40 feet. If wiring is to be longer, larger wiring is required. Additional information is available on request.

# SPECIFICATIONS

---

**SPECIFICATIONS:**

**Input:** 120 Volts, 60Hz, 1 amp

**Output Volts:** 13.25 volts nominal

**Output Current:** 0-3 Amps D.C. output current  
determined by state of charge of batteries

**Charge Indicator:** RED LED indicates charging current  
GREEN LED indicates fully charged

**Remote Charge Indicator Connector:** permits locating Red/Green LED's at  
remote loaction

**Weight:** 6 lbs

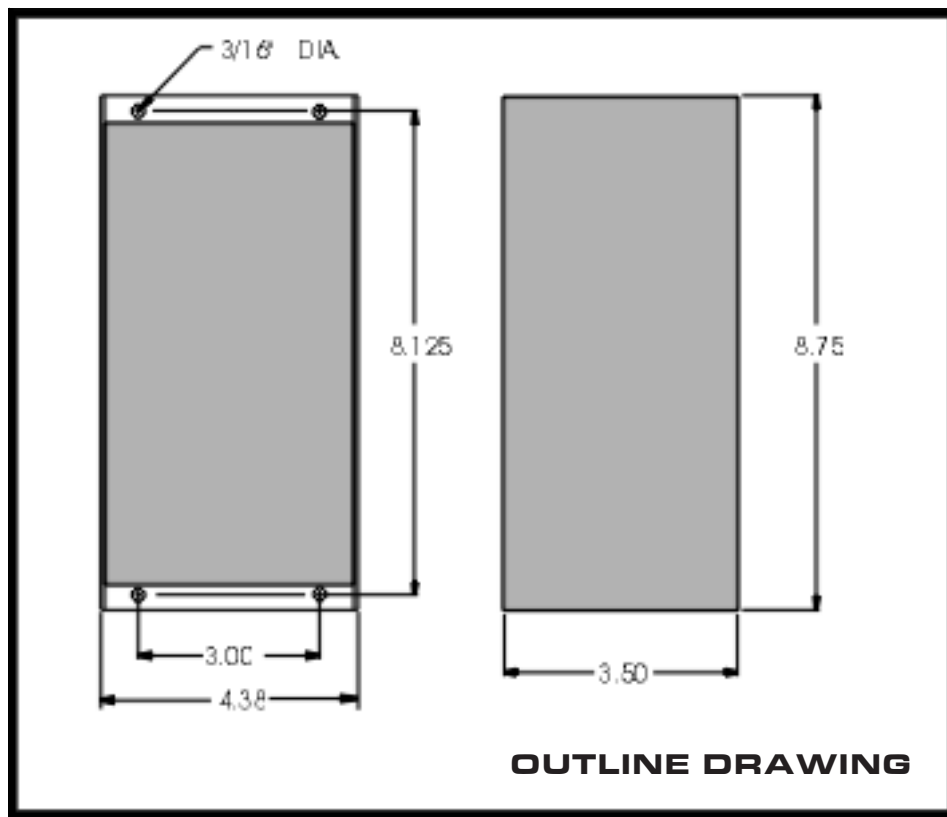

# INSTALLATION RECORD & WARRANTY

---

**Date Installed** \_\_\_\_\_

**Installed By** \_\_\_\_\_

**Vehicle Identification** \_\_\_\_\_

**Vehicle Owner** \_\_\_\_\_

## **WARRANTY**

All product of Kussmal Electronics Company Inc. are warranted to be free of defects of material or workmanship. Liability is limited to repairing or replacing at our factory, without charge, any material or defects which become apparent in normal use within 3 years from the date the equipment was shipped.

Kussmal Electronics Company, Inc. shall have no liability for damages of any kind to associated equipment arising from the installation and /or use of the Kussmal Electronics Company, Inc. products. The purchaser, by the acceptance of the equipment, assumes all liability for any damages which may result from its installation, use or misuse, by the purchaser, his or its employees or others.