

# BATTERY SAVER LOW RIPPLE HO

LOW RIPPLE POWER SUPPLY / AUTOMATIC LOAD SWITCH  
FOR 12VDC VEHICLE SYSTEMS



**MODEL # : 091-195-12**

**INPUT: 120 Volt, 50/60 Hz, 4.5 Amps RMS**

**OUTPUT: 13.2 Volts DC, 20 Amps**

File: IM\_091-195-12\_revE.indd  
Rev: E pg 6  
Revised By: PSS  
Date: 7-7-2015

3 YEAR WARRANTY



scan using your mobile  
device for more information

170 Cherry Avenue  
West Sayville, NY 11796  
www.kussmaul.com

**KE KUSSMAUL™  
ELECTRONICS**  
ENERGIZED AND READY, WHEN SECONDS COUNT

Ph: 800-346-0857  
Fax: 631-567-5826  
sales@kussmaul.com

# IMPORTANT SAFETY INSTRUCTIONS

---

## I. PERSONAL PRECAUTIONS:

1. Someone should be within range of your voice or close enough to come to your aid when you work near a lead-acid battery.
2. Have plenty of fresh water and soap nearby in case battery acid contacts skin, clothing, or eyes.
3. Wear complete eye and clothing protection. Avoid touching your eyes while working near a battery.
4. If battery acid contacts skin or clothing, wash immediately with soap and water. If battery acid enters the eye, immediately flood eye with cold running water for at least 10 minutes and get medical attention immediately.
5. **NEVER** smoke or allow a spark or flame in the vicinity of the battery or engine.
6. Be extra cautious to reduce the risk of dropping a metal tool onto the battery. It might spark or short-circuit the battery or other electrical part and cause a fire or an explosion.
7. Remove personal metal items such as rings, bracelets, necklaces, and watches when working with a lead-acid battery. A lead-acid battery, when shorted, can produce a current sufficient to weld a ring or the like metal causing a severe burn.
8. Use the battery charger for charging gel-cell, AGM and flooded lead-acid batteries only. Do not use the charger for charging dry-cell batteries that are commonly used with home applications. These batteries may burst and cause injury to persons and damage to property.
9. **WARNING – RISK OF EXPLOSIVE GASES:** Working in the vicinity of a lead-acid battery is dangerous. Batteries generate explosive gases during normal battery operation.

## II. CHARGER PRECAUTIONS:

1. **NEVER** charge a frozen battery.
2. Make sure the cord is located so that it will not be stepped on, tripped over, or otherwise subjected to damage or stress.
3. Do not operate the charger with a damaged cord or plug; replace them immediately.
4. Do not operate the charger if it has received a sharp blow, been dropped, or otherwise damaged.
5. Do not disassemble the charger. Incorrect reassembly may result in a risk of electric shock and fire.
6. To reduce the risk of electric shock, disconnect the charger from the AC source before attempting any maintenance or cleaning.
7. **LOCATION OF CHARGER:** The charger should be mounted on a wall, vehicle floor, ventilated compartment or other suitable surface as close to the batteries to be charged as possible. Do not block the charger's fan or air intakes. Do not mount the charger directly over the batteries as fumes may cause excessive corrosion. The area should be well ventilated and free from excessive moisture, exhaust manifolds, and battery fumes. For maximum performance, the charger should not be located in an area of extreme high temperature. The charger is not waterproof. Do not mount the charger where there is a possibility of water entering the unit. Evidence of water entry into the charger will void the warranty.
8. **CAUTION:** Do not attempt to increase battery bank capacity by splitting the output of one of the banks with a diode-type battery isolator. The diode isolator lowers the charger voltage and results in under-charging the batteries connected to it. If additional capacity is required it is preferable to add another isolated or parallel battery.

## III. GROUND AND AC POWER CORD CONNECTION:

1. The charger should be grounded via the AC power connection to reduce the risk of electrical shock.
2. The charger must be plugged into or wired to an outlet that is an over-current protected 3 prong outlet. Alternatively, it may be routed through a separate dedicated fuse or circuit breaker on an AC distribution panel with proper earth/safety ground. All wiring shall comply with UL recommendations, NEC or NFPA standards and local ordinances. Never alter the AC cord or plug if provided. Any modification of the cord must only be done by a qualified electrician. Improper cord/outlet connection may result in a risk of electrical shock.
3. Observe color coding of the AC wiring as follows:  

Black.....	AC Hot or LINE (fused)
White.....	AC Neutral
Green.....	AC Ground (safety/earth)
4. **CAUTION:** (230 VAC applications only): If AC input is provide from a source consisting of two HOT or LINE leads (phase-to-phase 230 VAC input voltage); an external fuse or circuit breaker must be used to protect both hot leads.

# INTRODUCTION

---

The Battery Saver Low Ripple (BSLR) is a power supply with a load power transfer function. Loads connected to the BSLR are powered by the vehicle's battery when the AC power to the BSLR is OFF. When AC power is applied to the BSLR special circuitry within the Battery Saver transfers the load(s) to the Battery Saver output. The Battery Saver output then provides low ripple 12VDC System power to Battery Saver load(s). Installation of a Battery Saver eliminates the power drain on a vehicle battery and or a battery under-charge ensuring all vehicle battery charger power is available to charge the battery. This Battery Saver is unique in that there is no interruption of power supplied to the loads during power transfers. The feature makes the BSLR ideal for Mobile Data Terminal (MDT) and or 12VDC vehicle computer systems that may "re-boot" during an input power interruption.

## FEATURES

---

### I. BATTERY SAVER LOW RIPPLE

- Clean, low ripple output causes no interference with sensitive electronics
- Relay removes auxiliary loads from vehicle battery and connects to battery saver, preventing battery discharge when in station
- Fast acting relay ensures "glitch" free power transfer
- Current limiting prevents overload
- Power "ON" LED status indicator
- Pump output with AC or DC mode rocker switch

### II. LED STATUS INDICATORS

1. **BATTERY CONNECTED:** Indicates that a battery of proper polarity is connected to the charger output terminals
2. **BATTERY SAVER ON LED:** Indicates that Battery Saver is receiving AC power and the power supply internal to the Battery Saver is ON.

## INSTALLATION INSTRUCTIONS

---

### I. WIRING AND MOUNTING THE BATTERY SAVER LOW RIPPLE HO

1. Mount the Battery Saver in a convenient location with 4 screws in the mounting holes provided. Be certain that adequate ventilation is available and the unit is not subject to weather damage.
2. Connect the 120VAC input power to the Battery Saver using the supplied IEC line cord as shown in INSTALLATION WIRING DIAGRAM, See Figure 1.
3. The low voltage connections are made through the DC output connector as shown in INSTALLATION WIRING DIAGRAM, See Figure 1.
4. Connect terminal 1 to the vehicle's 12 volt battery (+).
5. Connect terminal 2 to the vehicle ground or to the battery (-).
6. Connect terminal 3 to the +12 volt electrical loads.
7. The installation is now complete. Loads connected to the Battery Saver will be powered from the vehicle battery when the AC power to the Battery Saver is OFF and from the Battery Saver output when the AC power is ON.

## II. PRECAUTIONS

1. The Battery Saver Low Ripple HO is AC Input **AND** DC Output over-current protected as follows:
  - A. 120VAC 60Hz Input Fuse: 6.3 Amp
  - B. DC Output: ATC, 25 Amp

**Note:** The external ATC 20 Amp DC OUTPUT FUSE is common to both the Battery Saver output **AND** the vehicle battery connection that supplies power to the load when the Battery Saver is OFF (120VAC to Battery Saver - OFF).
2. OVERLOADING the Battery Saver in excess of 20 amperes when the BSLR is ON:
  - A. In excess of 20 amperes: initiate current limiting of the Battery Saver output with a corresponding reduction in output voltage.
  - B. In excess of 30 amperes: causes the ATC 25 Amp DC OUTPUT FUSE to open within 2 minutes.
3. OVERLOADING the Battery Saver in excess of 20 amperes when the BSLR is OFF:
  - A. When the BSLR is OFF, loads are powered by the battery, which is overload protected with an ATC 25 Amp fuse. The fuse will open when the current exceeds 30 amperes for 2 minutes

### Example:

A load of 25 amperes will cause the Battery Saver output to current limit with a corresponding decrease of output terminal voltage to less than 10.0 VDC. This same 25 ampere load WILL NOT cause the ATC 25 Amp fuse to immediately open when the load is connected to the vehicle battery via the BSLR.

Manage Battery Saver Connected Loads to 20 Amperes or Less!

## TEST AND OPERATION

---

### I. ELECTRICAL TEST

1. Remove AC power from the BSLR.
2. Verify "**BAT SVR ON**" LED is OFF and loads are being powered by vehicle battery (voltage at load is approximately equal to vehicle battery terminal voltage).
3. Apply AC power to BSLR and verify:
  - A. "**BAT CONNECTED**" remains illuminated.
  - B. "**BAT SVR ON**" LED illuminates approximately five (5) seconds after application of AC power to Battery Saver.
  - C. Load voltage is between 13.2 VDC and 14.0 VDC.

### II. OPERATION

The Battery Saver Low Ripple eliminates power delivery "glitches" or interruptions during load power transfer(s) from: Vehicle Battery to Battery Saver: Five (5) second delay as Battery Saver output stabilizes. Installation Test para. 3.2. Battery Saver to Vehicle Battery: No delay. The MINIMUM voltage at the load during any power transition is: Vehicle Battery VDC - 1.3VDC for a MAXIMUM of 150 milli-seconds (0.150 seconds).

# WIRING

## I. BATTERY SAVER LOW RIPPLE HO WIRING INSTRUCTIONS

1. Refer to Installation Wiring Diagram I. and II.
2. Refer to Wiring Specifications to determine the recommended wire size and maximum lengths. Using a smaller gauge may cause overheating of the terminal. Additional information is available upon request if longer, larger wiring is required.
3. Double check all wiring before applying AC power to input terminal.
4. Apply AC power (shoreline power) to input terminal and observe that the charger is operating.
5. Verify that the battery voltage appears at the charger output terminals. A minimum of 6 volts is required to start the charger.

## II. WIRING SPECIFICATIONS

Length of Wire to Battery (feet)	0 - 5			< 5 - 10			< 10 - 20*		
Battery Charger Connections	VBAT IN	COM	BS OUT	VBAT IN	COM	BS OUT	VBAT IN	COM	BS OUT
Wire # Gauge (awg)	12	12	12	12	12	12	10	10	10
* Consult factory if length of wire to battery is longer than 20 feet									

# INSTALLATION WIRING DIAGRAM

## I. WIRING DIAGRAM SHOWN IS FOR A 10 FOOT INSTALLATION

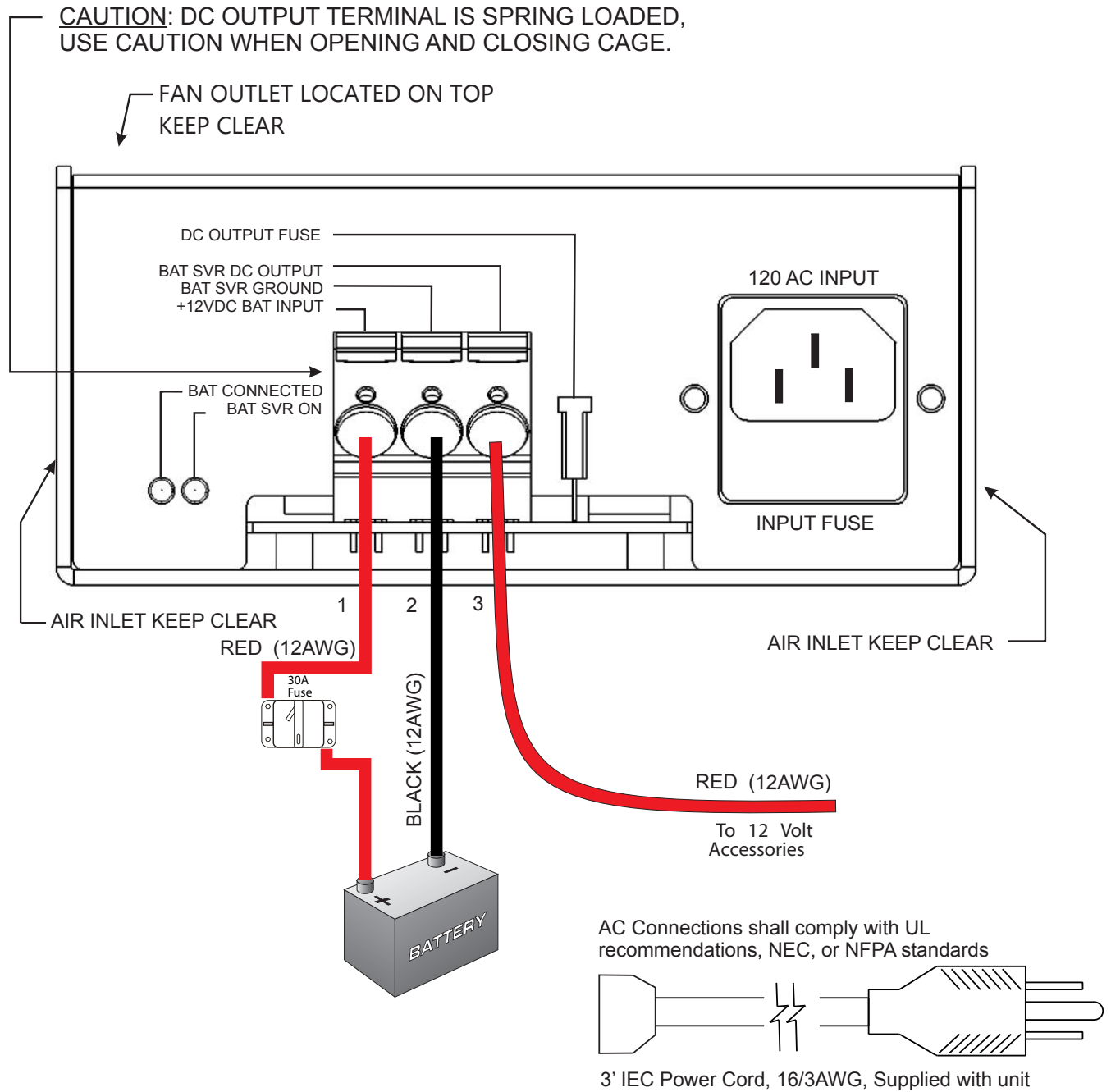

# SPECIFICATIONS

**Input Power:** 120 Volt, 50/60 Hz, 4.5 Amperes RMS

**Input Fuse:** (2) - 6.3 Amp, fast acting, 5 X 20mm

**Output Power:** 13.2 Volts DC, 20 Amperes Max

**Output Ripple:** 30 millivolts, AC., RMS

**Output Fuse:** 25 Amp, fast acting Autofuse, Please refer to Installation Precautions

**Electronic Current Limit:** 20 Amps D.C. from Battery Saver output, Please refer to Installation Precautions

**LED Status Indicators:** Battery Connected: Green LED, Battery Saver ON: Green LED

**Weight:** 4 pounds

# OUTLINE DRAWING

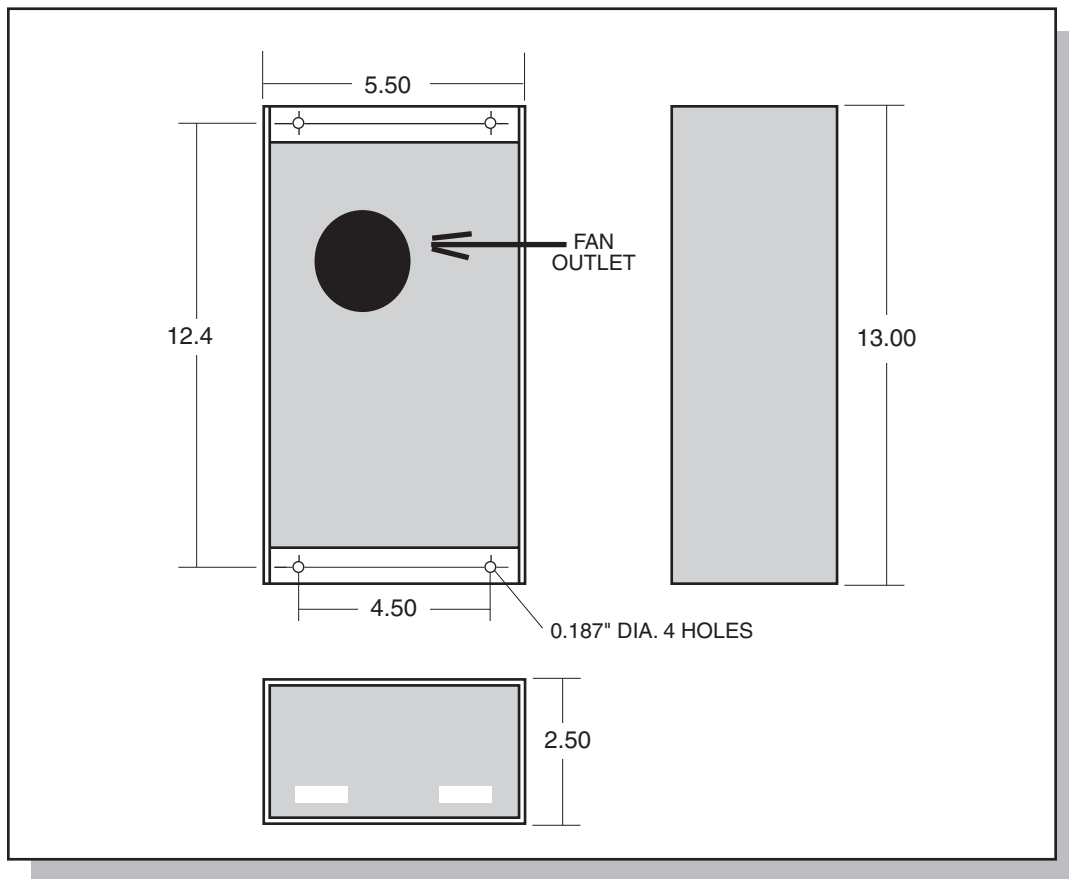

# INSTALLATION RECORD

---

DATE INSTALLED \_\_\_\_\_

INSTALLED BY \_\_\_\_\_

VEHICLE IDENTIFICATION \_\_\_\_\_

VEHICLE OWNER \_\_\_\_\_

# WARRANTY POLICY

---

All products of Kussmaul Electronics Company Inc. are warranted to be free of defects of material or workmanship. Liability is limited to repairing or replacing at our factory, without charge, any material or defects which become apparent in normal use within 3 years from the date the equipment was shipped. Equipment is to be returned, shipping charges prepaid and will be returned, after repair, shipping charges paid.

Kussmaul Electronics Company, Inc. shall have no liability for damages of any kind to associated equipment arising from the installation and/or use of the Kussmaul Electronics Company, Inc. products. The purchaser, by the acceptance of the equipment, assumes all liability for any damages which may result from its installation, use or misuse, by the purchaser, his or its employees or others.



Members of  
Fire and Emergency  
Manufacturers and  
Service Association



Members of  
National Fire  
Protection  
Association



Members of  
Fire Apparatus  
Manufacturers  
Association



---

170 Cherry Avenue  
West Sayville, NY 11796  
www.kussmaul.com



Ph: 800-346-0857  
Fax: 631-567-5826  
sales@kussmaul.com