

AUTO CHARGE 1200 REMOTE

AUTOMATIC SINGLE OUTPUT BATTERY CHARGER

Unit supplied with
one of these displays



MODEL #: 091-187-12-REMOTE

INPUT: 120 Volt, 60 Hz, 10 Amps

OUTPUT: 40 Amps

File: IM_091-187-12-remote_revD.indd
Rev: D (Added AGM/FLD)
Revised By: PSS
Date: 3-20-2015

3 YEAR WARRANTY



scan using your mobile
device for more information

170 Cherry Avenue
West Sayville, NY 11796
www.kussmaul.com



Ph: 800-346-0857
Fax: 631-567-5826
sales@kussmaul.com

IMPORTANT SAFETY INSTRUCTIONS

I. PERSONAL PRECAUTIONS:

1. Someone should be within range of your voice or close enough to come to your aid when you work near a lead-acid battery.
2. Have plenty of fresh water and soap nearby in case battery acid contacts skin, clothing, or eyes.
3. Wear complete eye and clothing protection. Avoid touching your eyes while working near a battery.
4. If battery acid contacts skin or clothing, wash immediately with soap and water. If battery acid enters the eye, immediately flood eye with cold running water for at least 10 minutes and get medical attention immediately.
5. **NEVER** smoke or allow a spark or flame in the vicinity of the battery or engine.
6. Be extra cautious to reduce the risk of dropping a metal tool onto the battery. It might spark or short-circuit the battery or other electrical part and cause a fire or an explosion.
7. Remove personal metal items such as rings, bracelets, necklaces, and watches when working with a lead-acid battery. A lead-acid battery, when shorted, can produce a current sufficient to weld a ring or the like metal causing a severe burn.
8. Use the battery charger for charging gel-cell, AGM and flooded lead-acid batteries only. Do not use the charger for charging dry-cell batteries that are commonly used with home applications. These batteries may burst and cause injury to persons and damage to property.
9. **WARNING – RISK OF EXPLOSIVE GASES:** Working in the vicinity of a lead-acid battery is dangerous. Batteries generate explosive gases during normal battery operation.

II. CHARGER PRECAUTIONS:

1. **NEVER** charge a frozen battery.
2. Make sure the cord is located so that it will not be stepped on, tripped over, or otherwise subjected to damage or stress.
3. Do not operate the charger with a damaged cord or plug; replace them immediately.
4. Do not operate the charger if it has received a sharp blow, been dropped, or otherwise damaged.
5. Do not disassemble the charger. Incorrect reassembly may result in a risk of electric shock and fire.
6. To reduce the risk of electric shock, disconnect the charger from the AC source before attempting any maintenance or cleaning.
7. **LOCATION OF CHARGER:** The charger should be mounted on a wall, vehicle floor, ventilated compartment or other suitable surface as close to the batteries to be charged as possible. Do not block the charger's fan or air intakes. Do not mount the charger directly over the batteries as fumes may cause excessive corrosion. The area should be well ventilated and free from excessive moisture, exhaust manifolds, and battery fumes. For maximum performance, the charger should not be located in an area of extreme high temperature. The charger is not waterproof. Do not mount the charger where there is a possibility of water entering the unit. Evidence of water entry into the charger will void the warranty.
8. **CAUTION:** Do not attempt to increase battery bank capacity by splitting the output of one of the banks with a diode-type battery isolator. The diode isolator lowers the charger voltage and results in under-charging the batteries connected to it. If additional capacity is required it is preferable to add another isolated or parallel battery.

III. GROUND AND AC POWER CORD CONNECTION:

1. The charger should be grounded via the AC power connection to reduce the risk of electrical shock.
2. The charger must be plugged into or wired to an outlet that is an over-current protected 3 prong outlet. Alternatively, it may be routed through a separate dedicated fuse or circuit breaker on an AC distribution panel with proper earth/safety ground. All wiring shall comply with UL recommendations, NEC or NFPA standards and local ordinances. Never alter the AC cord or plug if provided. Any modification of the cord must only be done by a qualified electrician. Improper cord/outlet connection may result in a risk of electrical shock.
3. Observe color coding of the AC wiring as follows:

Black.....	AC Hot or LINE (fused)
White.....	AC Neutral
Green.....	AC Ground (safety/earth)
4. **CAUTION:** (230 VAC applications only): If AC input is provide from a source consisting of two HOT or LINE leads (phase-to-phase 230 VAC input voltage); an external fuse or circuit breaker must be used to protect both hot leads.

INTRODUCTION

The Auto Charge 1200 Remote is a compact, completely automatic, single channel battery charger designed for vehicles with a single battery system. The charger is ruggedized to withstand the shock and vibration encountered by vehicle mounted equipment.

FEATURES

I. AUTO CHARGE 1200 REMOTE BATTERY CHARGER

- Electronic remote sensing of true battery voltage, eliminates the need for sensing wires
- Automatic current limiting
- Remote Battery charge/condition indicator display
- LED status indicators
- NEW! Battery Selector Switch (Lead-Acid/AGM)

II. CHARGE CONTROLS & ELECTRONIC REMOTE SENSING

The Auto Charge 1200 Remote contains a precision voltage controller to maintain the battery's charge. Automatic electronic remote sensing measures the true battery voltage, eliminating the need for the additional sense wires. The output current of any charger is inherently a series of pulses whose frequency is determined by the power line frequency. Therefore, there are brief intervals during which no charging current flows. Since there is no charging current there is also no voltage drop between the charger and the battery. The Auto Charge 1200 Remote thus measures and stores the true battery voltage. This battery voltage is compared to a reference voltage, any error detected is then used to control the charger output at the desired level. There is no "trickle charge" and therefore no danger of overcharging and water boil-off.

III. AUTOMATIC CURRENT LIMITING

When batteries are severely discharged, some battery chargers can be overloaded due to the high charging current required. The Auto Charge 1200 contains an automatic current limit. This circuit limits the output current to the rated 40 amperes when charging a deeply discharged battery or if the starter cranks the engine while charging. The current limiter thus eliminates the need for an ignition interlock circuit.

IV. LED STATUS INDICATORS

1. **BATTERY CONNECTED:** Indicates that a battery of proper polarity is connected to the charger output terminals
2. **FAN ON:** Indicates that the fan is operating. Fan operates whenever output exceeds 10 amperes. Fan turns off when output current decreases below 5 amperes
3. **POWER:** Indicates that AC voltage is present

IV. REMOTE BATTERY CHARGE CONDITION INDICATOR

This remote indicator shows the charge condition of each battery in 10 levels from “LOW CHARGE” to “FULLY CHARGED”. This device indicates a defective battery when a bar graph does not rise to the “FULLY CHARGED” level after an extended period of charging.

NOTE: If a battery is being charged with an external load of 1.5 to 4 amperes across it’s terminals, the bar graph may move down 1 or 2 levels. This does not indicate a defective battery.

To avoid this, connect all external loads to the Battery Saver terminals.

Loads connected to the Battery Saver will be powered either from the Battery Saver power supply when the A.C. power is “ON”, or they will be connected to battery #1 when the A.C. power is “OFF”.

VI. BATTERY SELECTOR SWITCH

Used to select between Lead-Acid or AGM batteries. The selector switch is factory set to Lead-Acid.

WIRING

I. BATTERY CHARGER WIRING INSTRUCTIONS

1. Refer to Installation Wiring Diagram I. and II.
2. Refer to Wiring Specifications to determine the recommended wire size and maximum lengths. Using a smaller gauge may cause overheating of the terminal. Additional information is available upon request if longer, larger wiring is required.
3. Make sure the position of the Battery Selector Switch matches the battery type. The switch is factory to Lead-Acid. Switch to AGM when using AGM style batteries. Refer to Wiring Diagram III.
4. Double check all wiring before applying AC power to input terminal.
5. Apply AC power (shoreline power) to input terminal and observe that the charger is operating.
6. Verify that the battery voltage appears at the charger output terminals. A minimum of 6 volts is required to start the charger

II. WIRING SPECIFICATIONS

Length of Wire to Battery (feet)	0 - 5		< 5 - 10**		< 10 - 20*	
	V. BAT +	COM -	V. BAT +	COM -	V. BAT +	COM -
Battery Charger Connections	8	8	6	6	4	4
Wire Ferrule Used	091-TERFER812		091-TERFEB612		None	
* Consult factory if length of wire to battery is longer than 20 feet						
** Supplied with wire terminal hardware for 10 foot installation						

INSTALLATION WIRING DIAGRAM

I. FOR BAR GRAPH DISPLAY, 091-199-001 OR DELUXE STATUS CENTER, 091-194-IND

Wiring Diagram shown is for a 10 foot installation

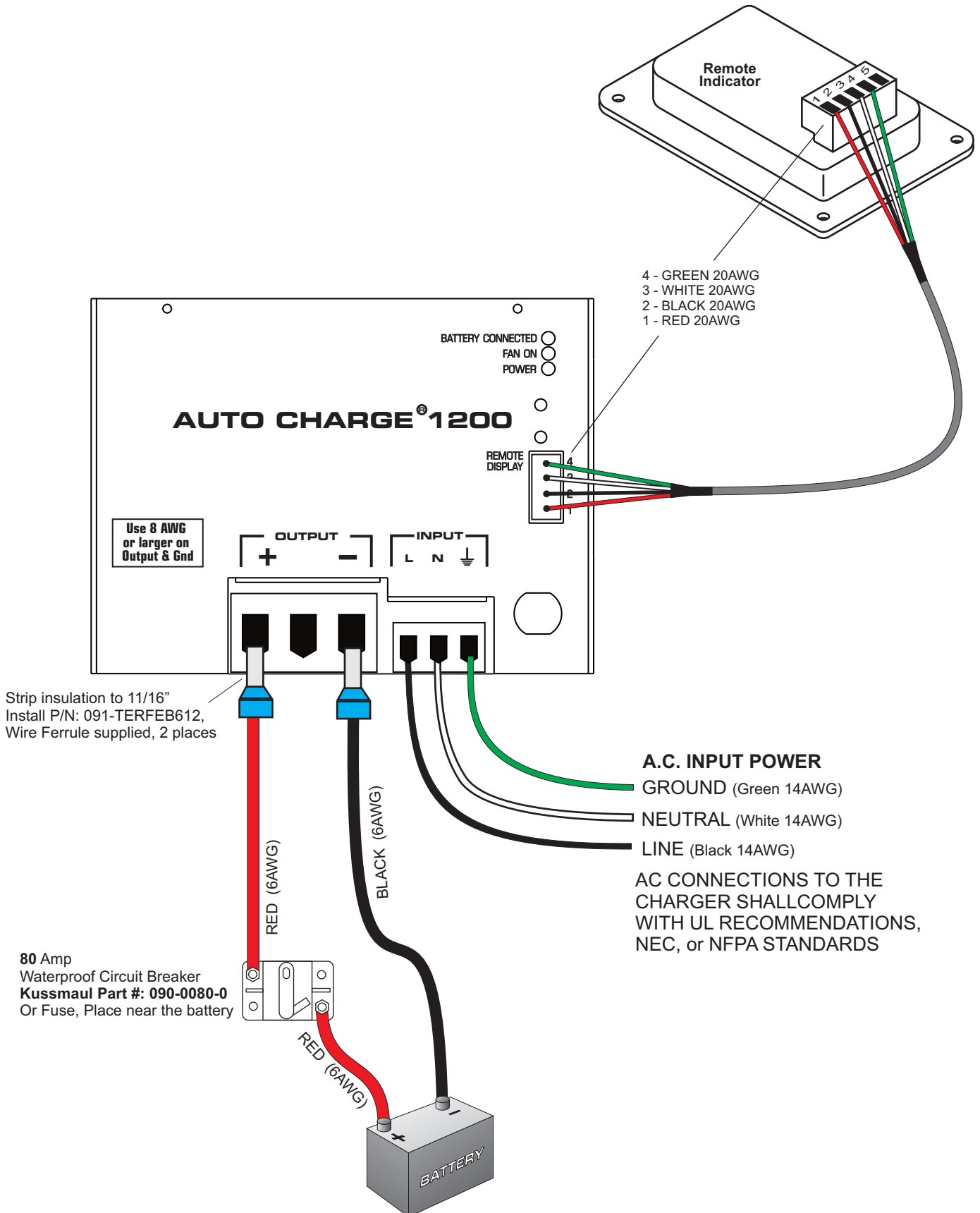

II. FOR WATERTIGHT DELUXE STATUS CENTER, 091-194-IND-WT-XX

Wiring Diagram shown is for a 10 foot installation

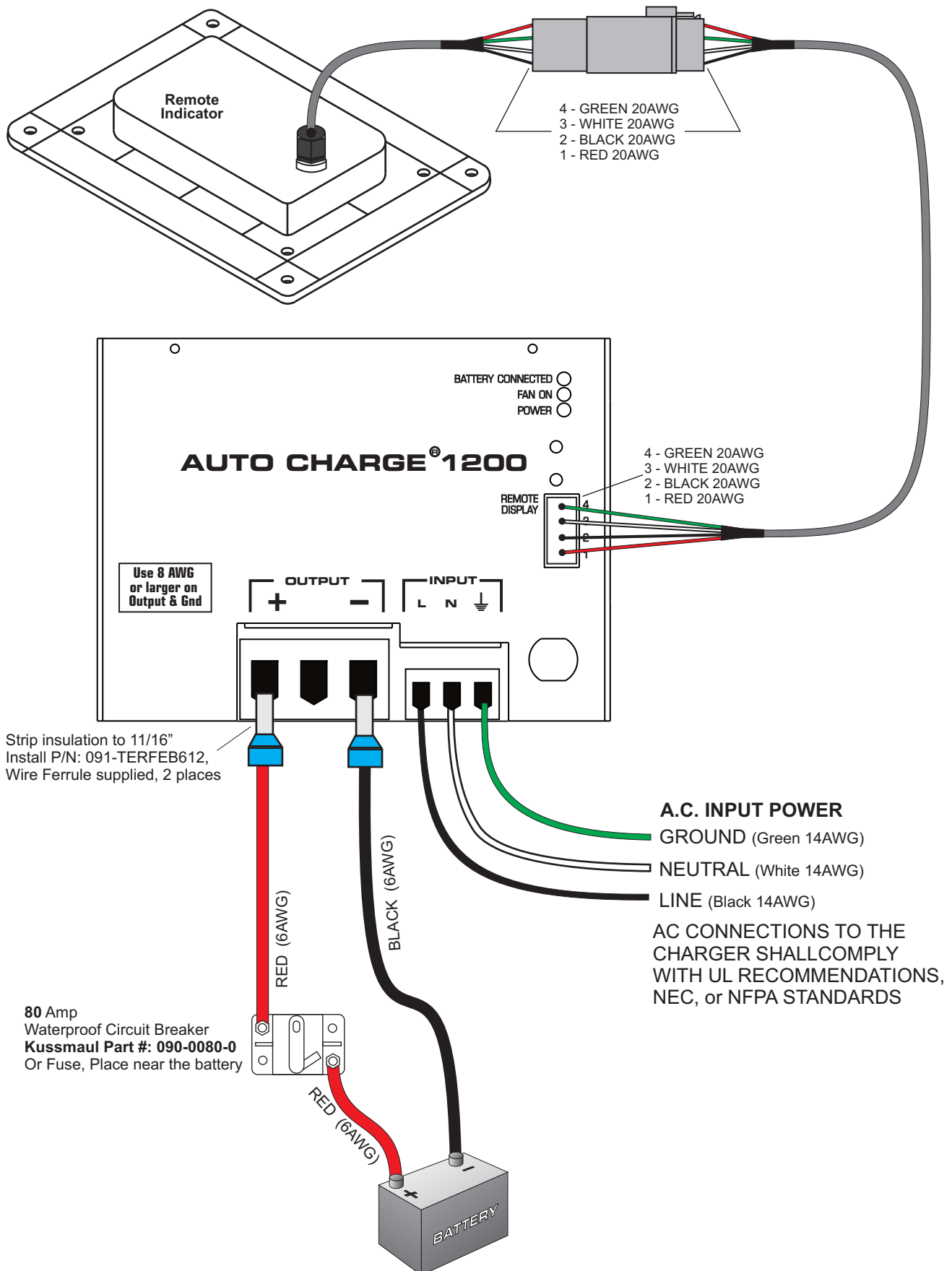

BATTERY SELECTOR SWITCH

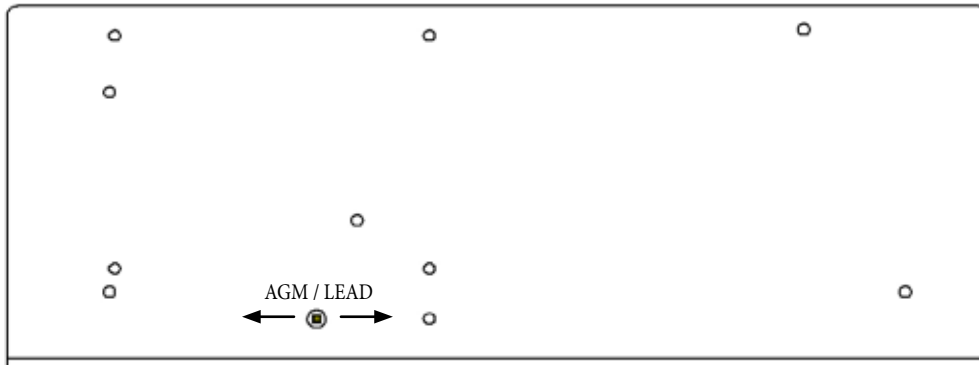

Use a mini precision
slotted screwdriver to
select AGM or Lead-Acid

SPECIFICATIONS

Input Power: 120 Volt, 60 Hz, 10 Amperes

Input Fuse: 15 Ampere, resettable, circuit breaker

Output Power: 12 Volts DC, 40 Amperes Max

Remote Sensing: Electronic, sense wires not required

Torque: DC output connector: 20 in. lbs

LED Status Indicators: Battery Connected, Fan On, and Power On

Battery Selector Switch: (Lead-Acid / AGM): Lead-Acid Float = 13.25VDC; AGM Float = 13.50VDC

Hardware Pack Provided: (2) #6 AWG Blue Ferrules, P/N: 091-TERFEB612

Charger Indicators: Remote Bar Graph Display, Deluxe Status Center or Waterproof Status Center

Output Waterproof Circuit Breaker (Optional): 80 Amperes, P/N: 090-0080-0

Output Buss Bar (Optional): 5 Studs, P/N: 002-3595-5

Weight: 26 pounds

OUTLINE DRAWING

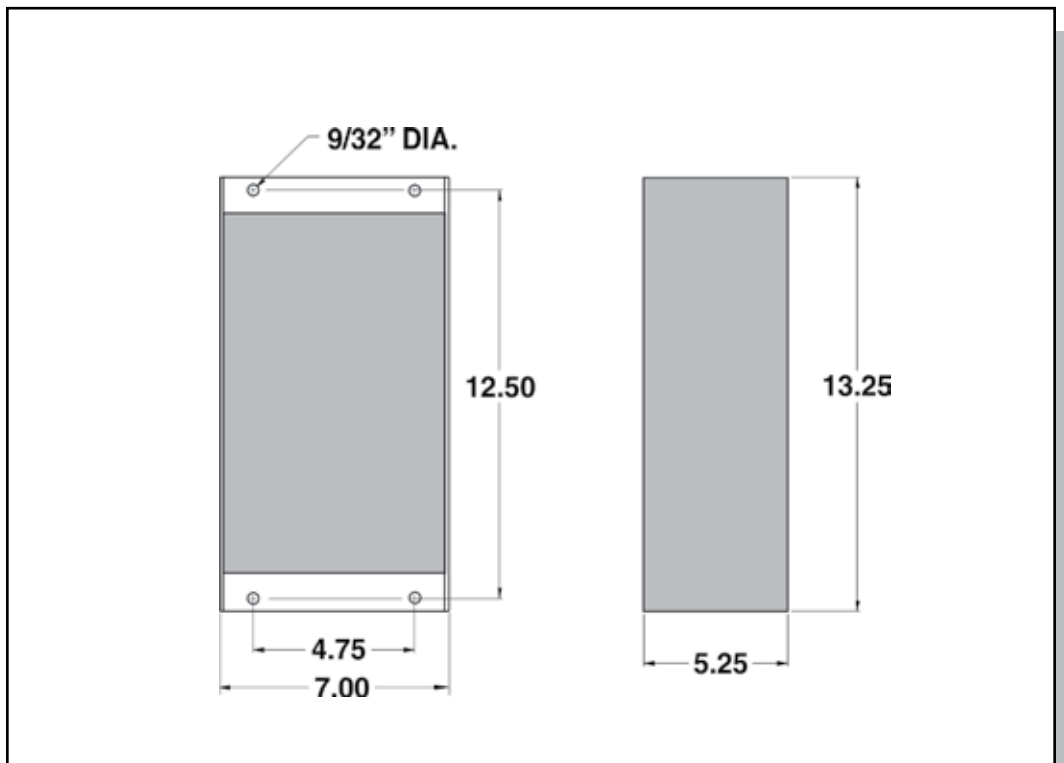

OPTIONAL ACCESSORIES

I. BAR GRAPH DISPLAY, MODEL #: 091-199-001

- 10-Segment LED display indicate the “state of charge” and the general condition of the batteries



II. DELUXE STATUS CENTER, MODEL #: 091-194-IND

- Indicator has a digital voltage and ampere display
- 5 segment bar graph display indicates output current
- 4 LED's to show the condition of the batteries

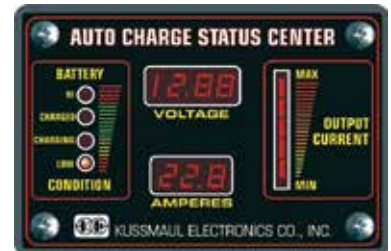

III. WATERTIGHT DELUXE STATUS CENTER, MODEL #: 091-194-IND-WT-XX

- Indicator has digital voltage and ampere display
- 5 segment bar graph display indicates output current
- 4 LED's to show the condition of the batteries
- Indicator is housed in a watertight bezel
- Bezel is available in 6 different colors, Red, White, Blue, Yellow, Gray, and Black
- Specify color choice when ordering



IV. WATERPROOF CIRCUIT BREAKER, MODEL #: 090-0080-0

- Combines switching and circuit breaker function
- Compact size and surface mount configuration
- Protects high amperage circuits
- Latch arms resets breaker after overload
- Cannot be held in ON position if short remains on circuit
- Waterproof - Ideal for truck applications



V. E-Z SLIDE MOUNTING PLATE, MODEL #: 091-200-EZM

- Locking mounting system
- Ease the installation and the removal of larger sized chargers that are in harder to access areas, such as under seats



INSTALLATION RECORD

DATE INSTALLED _____

INSTALLED BY _____

VEHICLE IDENTIFICATION _____

VEHICLE OWNER _____

WARRANTY POLICY

All products of Kussmaul Electronics Company Inc. are warranted to be free of defects of material or workmanship. Liability is limited to repairing or replacing at our factory, without charge, any material or defects which become apparent in normal use within 3 years from the date the equipment was shipped. Equipment is to be returned, shipping charges prepaid and will be returned, after repair, shipping charges paid.

Kussmaul Electronics Company, Inc. shall have no liability for damages of any kind to associated equipment arising from the installation and/or use of the Kussmaul Electronics Company, Inc. products. The purchaser, by the acceptance of the equipment, assumes all liability for any damages which may result from its installation, use or misuse, by the purchaser, his or its employees or others.



Members of
Fire and Emergency
Manufacturers and
Service Association



Members of
National Fire
Protection
Association



Members of
Fire Apparatus
Manufacturers
Association



170 Cherry Avenue
West Sayville, NY 11796
www.kussmaul.com



Ph: 800-346-0857
Fax: 631-567-5826
sales@kussmaul.com