

INSTRUCTION MANUAL

AUTO CHARGE 24/12 HO AUTOMATIC BATTERY CHARGER



MODEL # 091-175

INPUT: 115 Volt, 60 hz, 7 amps

**OUTPUT: 12 Volt, 25 amps
24 Volt, 6 amps
battery system.**

3 YEAR WARRANTY

INTRODUCTION

The Auto Charge 24/12 HO, Model 091-175, Battery Charger is a compact completely automatic charger designed for installation on vehicles with a 24V and 12V battery. The voltage of the battery connected to the Auto Charger 24/12 HO is sensed via the charging cables so that the battery is charged according to its requirements. An optional remote display provides continuous indication of the charger output.

Construction of the Auto Charge 24/12 HO is extremely rugged to withstand the shock and vibration normally encountered by vehicle mounted equipment. The unit operates completely automatically and stops charging the batteries when they are fully charged. There is no trickle charge and therefore no danger of overcharging and water boil-off. Any parasitic loads on the battery such as radio, lights, etc., are automatically supplied with current by the charger.

INSTALLATION

The Auto Charge 24/12 HO, Model 091-175 Automatic Battery Charger should be installed in an area with adequate ventilation. A power cord is supplied for connection to shore line.

1. Mount the charger using the four holes located in the front and rear of the charger.
2. Connect the wiring from the battery to the Output Terminal Strip. Ferrule lugs that have been securely crimped or soldered should be used.
3. Double check all wiring before proceeding.
4. Pilot light will light to show that the charger has power.

INSTALLATION WIRING DIAGRAM

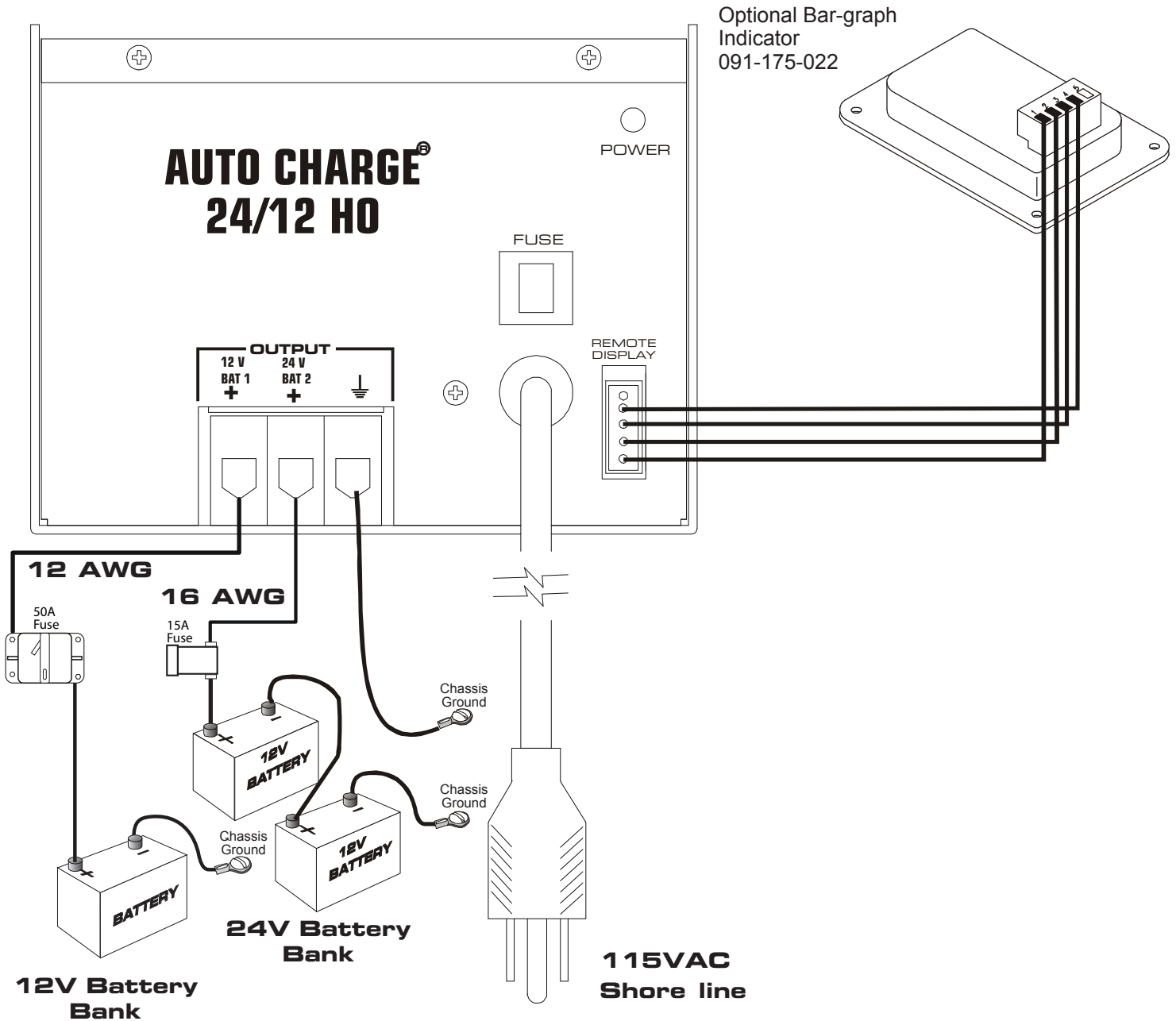

IMPORTANT:

NOTE1: Wire size is for a maximum length of 20 feet. If wiring is to be longer, larger wiring is required. Additional information is available on request.

NOTE2: If fuse is blown, to reset wait 5 minutes for cooling and press the fuse switch on the front panel.

OUTLINE

SPECIFICATIONS:

Input: 115 volt, 60hz, 7 amperes

Input breaker: 12 amp fuse breaker

Output: 12 V supplies 25 amperes max
24 V supplies 6 amperes max

Weight: 23 lbs

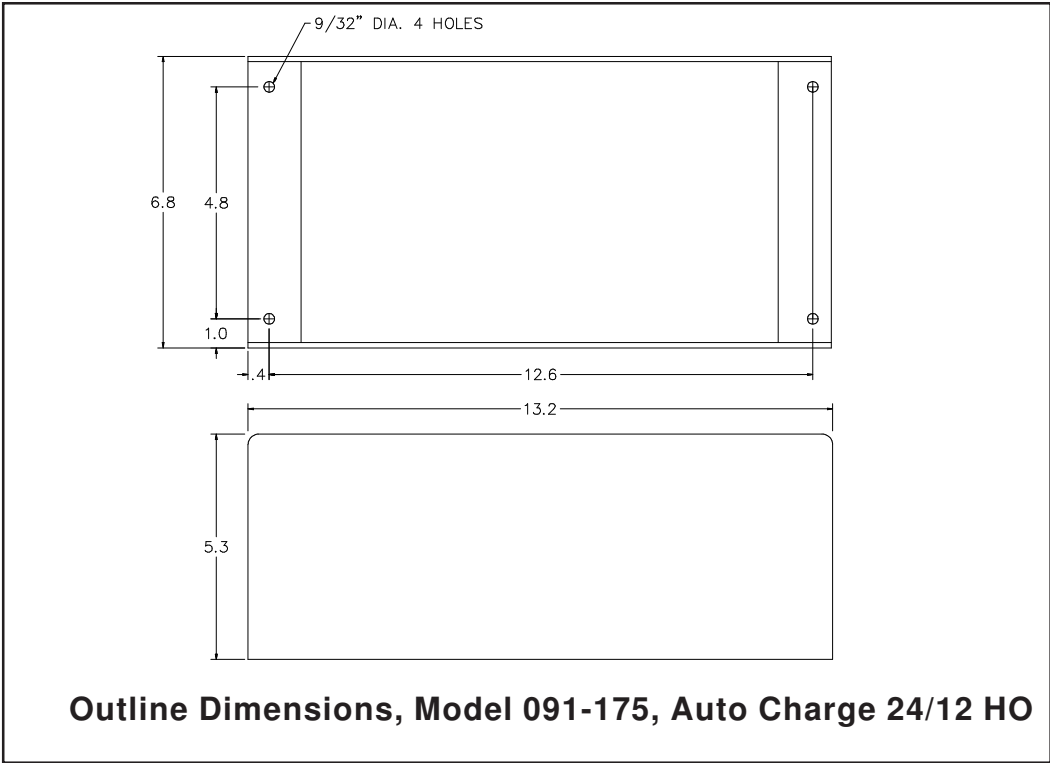

Outline Dimensions, Model 091-175, Auto Charge 24/12 HO

INSTALLATION RECORD & WARRANTY

Date Installed _____

Installed By _____

Vehicle Identification _____

Vehicle Owner _____

WARRANTY

All product of Kussmaul Electronics Company Inc. are warranted to be free of defects of material or workmanship. Liability is limited to repairing or replacing at our factory, without charge, any material or defects which become apparent in normal use within 3 years from the date the equipment was shipped.

Kussmaul Electronics Company, Inc. shall have no liability for damages of any kind to associated equipment arising from the installation and /or use of the Kussmaul Electronics Company, Inc. products. The purchaser, by the acceptance of the equipment, assumes all liability for any damages which may result from its installation, use or misuse, by the purchaser, his or its employees others.

