

Model: DCV DC Voltmeter



INSTALLATION/OPERATION MANUAL

Introduction

The DCV Battery Voltmeter provides accurate low cost digital instruments for 3 banks of batteries between 9.5 and 33 Volts. The instrument displays battery voltage for any one of three banks. You can set Low and High voltage alarms for each bank independently and the DCV continuously monitors the voltage of each bank at all times. When activated, the built-in 85 dB alarm will sound and the display will flash. Five levels of backlighting can be selected and all set-up, calibration constants and alarm values are saved to non-volatile memory. You can select to have either an external alarm output or standard NMEA 0183 compatible data alarm output. If you select NMEA 0183, the voltage of each battery is output once per second as 4800 BAUD serial data stream.

Installation

Before starting the installation, please read this entire section first. The instrument may be installed in a bulkhead or in NEWMAR's Single or Dual Universal Meter Panel Blanks (contact factory). Remove the rear bracket, attach wiring as explained in the following section, then reassemble and install as shown in the diagram below. Finger tighten the nuts that secure the bracket - do not use tools. (You may use Lock-Tite to keep the nuts from vibrating loose.) Be sure to slide the bulkhead gasket over the instrument body before you install the instrument.

Drill a 2-1/8" (55mm) mounting hole (or use NEWMAR's Single or Dual Universal Meter Panel Blanks) as shown in FIGURE 1.

FIGURE1

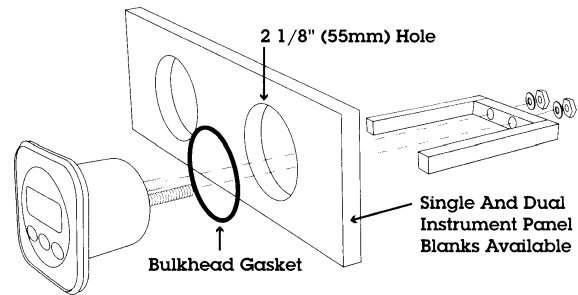

Bring the wires out the mounting hole and make the connections to the screw terminal on the instrument case as shown on FIGURE 2 and FIGURE 3.

Note: For proper operation, all three battery inputs **MUST** be connected to 9.6 VDC minimum. For installations with fewer than three battery banks, jumper spare terminals (E) or (F) to terminal (B).

FIGURE2

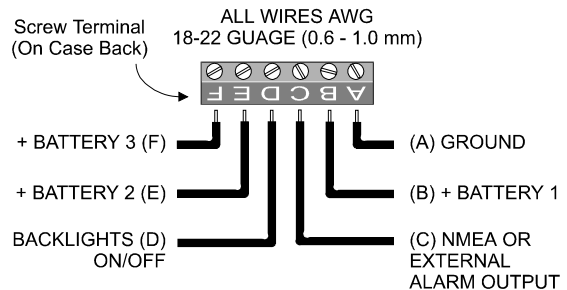

(FIGURE3ONREVERSE)

M-02343480
OCT 2010

FIGURE 3

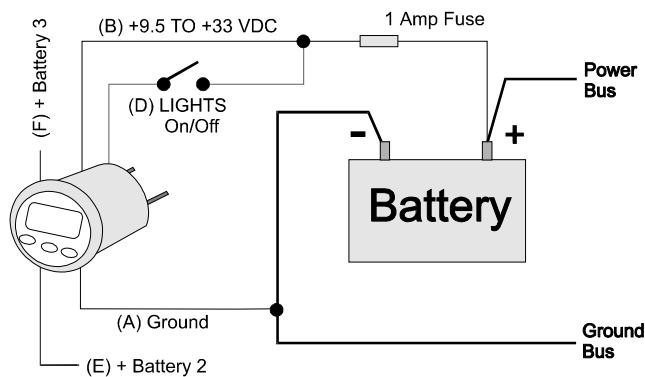

Carefully check all your wiring against that shown in FIGURES 2 and 3. If everything is wired correctly you can mount the DCV in the instrument hole. Be sure the bulkhead gasket is in place and use only finger tension to tighten the bracket hold-down nuts. *Do not overtighten the bracket or you may damage the case - do not use tools to tighten the nuts.*

Operation

Key Functions

The **1** **2** **3** keys are used to select what to display, backlights, calibrate volts/amps, turn alarms on/off, and set alarms values. New information is automatically saved to memory.

Turning Alarms ON/OFF

Press the **1** key 1/2 second to turn alarms ON. The Battery (1, 2, or 3) icon will blink. Press the **2** key 1/2 second to turn the alarms OFF.

Backlight Intensity

Press **3** the key 1/2 second to adjust the backlight level for night-time viewing. Each time you press the **3** key 1/2 second, the level will get brighter 1, 2, 3, 4, OFF, 1, 2...etc. Screw terminal pin (D) must be switched on for the backlights to work.

Display Volts for Battery 1, 2, or 3

Quick press one of the **1** **2** **3** keys to select Battery 1, 2, or 3.

Setting High Volts Alarm

Select the battery (1, 2, or 3) for which you wish to set the High Volts Alarm. Press and hold the **1** key for ten (10) seconds. You will hear a beep and the High Volts alarm value for that battery will be displayed. Use the **1** and **2** keys to set the desired alarm value. Press the **3** key to save the High Volts Alarm value to memory.

Setting Low Volts Alarm

Select the battery (1, 2, or 3) for which you wish to set the Low Volts Alarm. Press and hold the **2** key for ten (10) seconds. You will hear a beep and the Low Volts alarm value for that battery will be displayed. Use the **1** and **2** keys to set the desired alarm value. Press the **3** key to save the new alarm value.

Calibrating the Instrument

The DCV is calibrated at time of manufacture for 12V battery banks, but can be calibrated at any time by using the front panel keys. Battery 1, 2, or 3 can be independently calibrated. To calibrate the voltmeter, press and hold down one of the **1** **2** **3** keys for three seconds (to calibrate battery 1, 2, or 3) while applying power to the instrument. Use the **1** and **2** keys to make the displayed value read correctly. Press the **3** key to save the calibration data to memory.

Selecting NMEA 0183 or External Alarm Output

The DCV comes factory pre-set to output NMEA 0183 compatible serial data. If you do not need this feature or would rather have an external alarm output on screw terminal (C), you can do so as follows.

While viewing battery voltage (any battery), press and hold down both the **1** and **2** keys for 10 seconds (until you hear a long beep). This operation switches the output mode between NMEA 0183 and External Alarm. The new output mode is automatically saved to memory.

When the external alarm output is activated, a 5V signal (10 mA Max.) is output on screw terminal (C).

Warnings and Notes

1) The DCV receives power from the connection to Battery 1 (screw terminal B), **but requires that the Battery 2 and Battery 3 inputs (screw terminals E and F) also be connected to at least 9.5 VDC for proper operation.** For installations with fewer than three battery banks, jumper the spare terminals to terminal B (or connect them directly to Battery 1).

2) Screw terminal (D) must be connected to 9.5 VDC minimum in order for the backlights to turn ON. If screw terminal (D) is not connected to at least 9.5 VDC the backlights will turn OFF. This provides remote control of the backlights.

NMEA 0183 Sentences

The DCV outputs a 4800 BAUD serial data stream of battery volts for battery 1, 2, or 3 once per second. The NMEA sentence identifies the instrument (V-30) and the battery (1, 2, or 3).

Volts: \$IIXDR,U,xx.x,V,V301,*CS (for battery 1)

Volts: \$IIXDR,U,xx.x,V,V302,*CS (for battery 2)

Volts: \$IIXDR,U,xx.x,V,V303,*CS (for battery 3)

*CS = Check Sum

Specifications

Power supply: 9.5 to 33.0 VDC, .018 amps nominal

Operating temperature: 32 to 122°F (0 to 50°C)

Size: 2.5" dia X 4.1" deep (61mm x 104 mm).

Accuracy: Better than +/- 0.1 VDC front panel adjustable independently for each bank.

Ranges: Volts 1, 2, & 3 - 9.5 to 33.0 VDC

Alarms: Independent High and Low Voltage Alarms for each Battery

Display: 4 digit LCD, 5 levels of backlighting.

Output: 4800 BAUD Serial Data; \$IIDR output once per second for each bank OR external alarm output (user selectable).