

END IDLING IN YOUR FLEET

SYSTEM BENEFITS:

- IMPROVE OPERATOR SAFETY
- ENGINE-OFF AIR CONDITIONING
- REDUCE OPERATING COST
- PROTECT THE ENVIRONMENT
- LIGHT WEIGHT
- SMALL FORM FACTOR

EM100E48V

ZeroRPM energy modules are a safe and space efficient solution when you want to add lithium power to your vehicle. This module is designed to power lights, radios, computers, inverters and other electronics with your engine off. Energy Modules of the same voltage may be added in parallel to increase the run time of your system. Energy modules contain an on-board battery management system. ZeroRPM energy modules use lightweight *lithium-iron batteries. This chemistry makes ZeroRPM battery technology among the safest on the market. This unit can be charged using 48V power from an alternator, solar panels, or other 48V power source.

Note: This product requires other ZeroRPM IMS components. Reference ZeroRPM.com/systems for more information.

**"Lithium-Iron" is marketing term for ZeroRPM's LiFeMnPO4 packaged energy storage systems.*

SPECIFICATIONS:

Total Energy	5.12 kWh
Usable Energy	4.00 kWh
Current Limit Export	250A @ 100% Duty Cycle @48V
Export Voltage	48V-56.4V
Charge Voltage	48V-56.8V
Nominal Voltage	51.2V
Battery Chemistry	Lithium-Iron (LiFeMnPO4)
Internal Fuse Rating Battery Protection (Slow Blow)	300A
Product Housing Material	Powder-coated Galvanized Steel and Aluminum
Weight	~140 lbs / ~63.5 kg
Charging Temperature Range*	32°F to 150°F / 0°C to 65.6°C
Discharge Temperature Range*	-4°F to 150°F / -20°C to 65.6°C
Number of 12V Battery Packs	4

*Temperatures are based on software versions 4.94.00 and later with battery SOC of >40%.

**6" CLEARANCE
 NEEDED FOR
 CONNECTIONS**

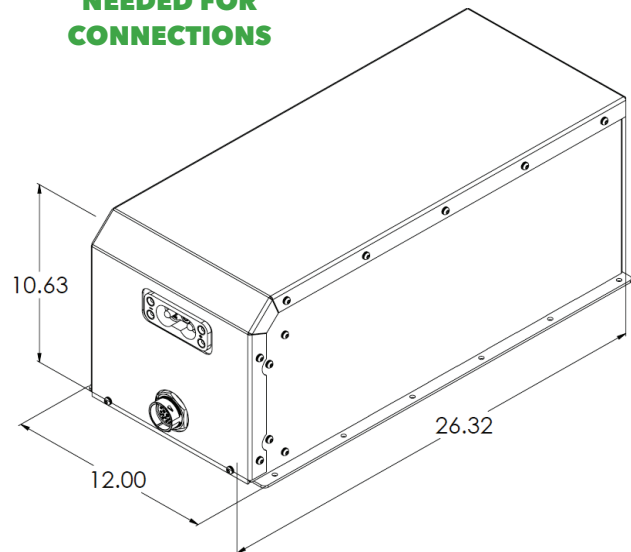

Ask for ZeroRPM® Idle Mitigation Systems® WHERE you purchase your fleet vehicles!

EM100E48V

ALL DIMENSIONS ARE IN INCHES

FOR WIRING OF THE SYSTEM PLEASE REFERENCE THE SYSTEM SCHEMATIC

6" CLEARANCE NEEDED FOR CONNECTIONS

OVERALL DIMENSIONS

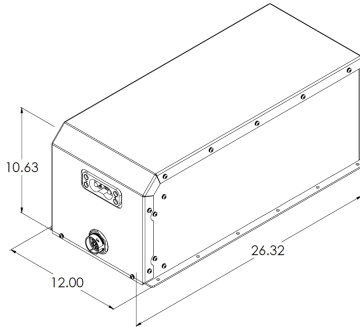

FRONT



SIGNAL CONNECTION



31 PIN BATTERY MANAGEMENT CONNECTOR

POWER CONNECTION



48V POWER 2-CABLE REBLING CONNECTOR

TOP

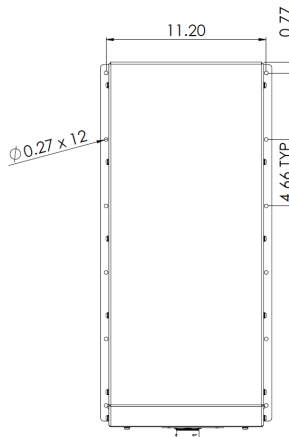

SIDE

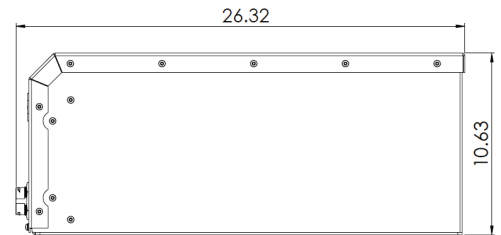

PRODUCT NOTES:

- Storage temperature: -4 °F to 149 °F / -20 °C to 65 °C.
- The unit must be mounted securely and upright.
- In shipping or storage, do not stack more than one product on top of one another (i.e. two unit stack maximum).
- The unit must be mounted so the lid is removable.
- The unit must be mounted as closely to the loads and supply as possible.
- If the unit has been in storage for more than 90 days, the voltage must be checked to ensure that the batteries have not discharged past the acceptable threshold.
- There must be adequate provisions for drainage below the unit to prevent flooding.
- There must be at least 6" of clearance on the right side of the unit for the main power connectors.
- The unit must be mounted in a well-ventilated compartment. In extreme hot or cold environments, it is ideal to mount the unit in a temperature controlled compartment.
- The unit must be mounted with vibration-dampening material. The material must be installed between the unit's feet and the mounting surface.
- Exporting at maximum current for an extended amount of time will substantially reduce the life of the battery pack.
- Do not put the unit on its side or upside down without written approval from ZeroRPM.
- Do not extend the current shunt wires (if current shunt wires are present).